

## MINI UHV GATE VALVE, SERIES 01.0

General purpose valve for isolation in UHV or other demanding applications.



Free of lubricants

Low particle generation

Low shock

Vulcanized gate seal (see glossary)

### MAIN FEATURES

Sizes	DN 16 – 50 mm ( $\frac{5}{8}$ " – 2")
Actuators	manual with turning handle pneumatic: single acting with closing spring (NC) or opening spring (NO), or double acting
Body material	stainless steel
Feedthrough	bellows
Standard flanges	ISO-KF, CF-F
Sealing technology	MONOVAT (see glossary)

### FUNCTIONAL PRINCIPLE

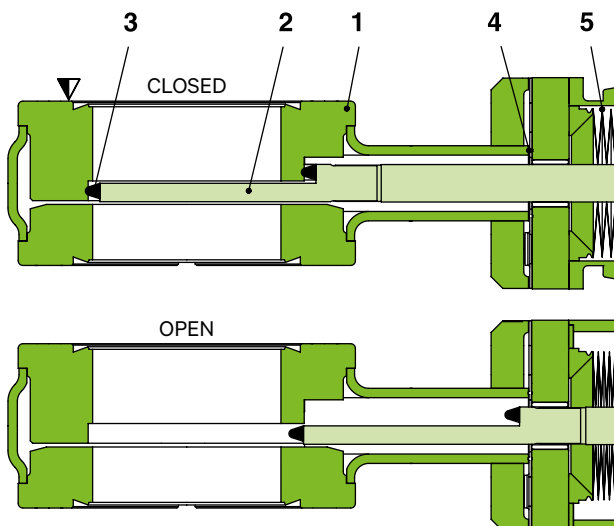

- 1 Valve body
- 2 Gate
- 3 Gate seal
- 4 Bonnet seal
- 5 Bellows
- ▼ Valve seat side

## TECHNICAL DATA

Leak rate	Valve body	$< 5 \cdot 10^{-10}$ mbar ls <sup>-1</sup>
	Valve seat	$< 1 \cdot 10^{-9}$ mbar ls <sup>-1</sup>
Pressure range		1 · 10 <sup>-10</sup> mbar to 2 bar (abs)
Differential pressure on the gate		≤ 2 bar
Differential pressure at opening		≤ 30 mbar
Cycles until first service		50 000
Temperature <sup>1)</sup>	Valve body	≤ 250 °C open / ≤ 200 °C closed
	Manual actuator	≤ 250 °C
	Pneumatic actuator	≤ 200 °C
	Solenoid valve	≤ 50 °C
	Position indicator	≤ 80 °C
Heating and cooling rate		≤ 50 °C h <sup>-1</sup>
Material	Valve body	AISI 304 (1.4301), AISI 316L (1.4435)
	Mechanism	AISI 304 (1.4301),
	Bellows	AISI 316L (1.4435)
Seal	Bonnet	metal
	Gate	FKM (Viton®)
Feedthrough		bellows
Mounting position		any
Solenoid valve	Actuator with closing or opening spring	24 V DC, 9.0 W (others on request)
	Actuator double acting	24 V DC, 5.4 W (others on request)
Position indicator: contact rating	Voltage	≤ 250 V AC    ≤ 50 V DC
	Current	≤ 5 A            ≤ 3 A
Valve position indication		visual (mechanical)

				Valve with manual actuator			Valve with pneumatic actuator								
DN (nominal I.D.)		Conductance (molecular flow) (depending on A-dimension and flange type)		Turns per stroke	Weight		Compressed air min. – max. overpressure		Volume of pneumatic actuator		Closing or opening time	Weight			
mm	inch	ls <sup>-1</sup>	ls <sup>-1</sup>		kg	lbs	bar	psi	l	ft <sup>3</sup>		kg	lbs	kg	lbs
16	5/8	9	–	5	1.50	3.30	5–7	73–102	0.10	0.004	0.70	4.20	9.26	2.20	4.85
25	1	38	–	5	1.50	3.30	5–7	73–102	0.10	0.004	0.70	4.20	9.26	2.20	4.85
40	1½	160	220	5	1.50	3.30	5–7	73–102	0.10	0.004	0.70	4.20	9.26	2.20	4.85
50	2	160	–	5	1.50	3.30	5–7	73–102	0.10	0.004	0.70	4.20	9.26	2.20	4.85

<sup>1)</sup> Maximum values: depending on operating conditions and sealing materials.

## OPTIONS, CUSTOMIZED SOLUTIONS

### ACTUATOR

- Solenoid valve for impulse actuation:  
last valve position is maintained at power failure
- Solenoid valve separate, for external mounting
- Other solenoid valve voltage (standard 24VDC)
- Manual emergency operation on solenoid valve lockable
- Manual actuator with position indicator
- Bakeable position indicator with connection cable 0.3 m:  
actuator bakeable to max. 200 °C, contact rating  $\leq 50$  V AC/DC,  $\leq 1$  A

### VALVE

- Customer specified flanges
- Insert version (without body, for integration into the vacuum system)
- Other sealing materials
- With protective ring: see series 17
- Special gate for the installation of various foils or orifices
- Window in gate (Dia. 1)

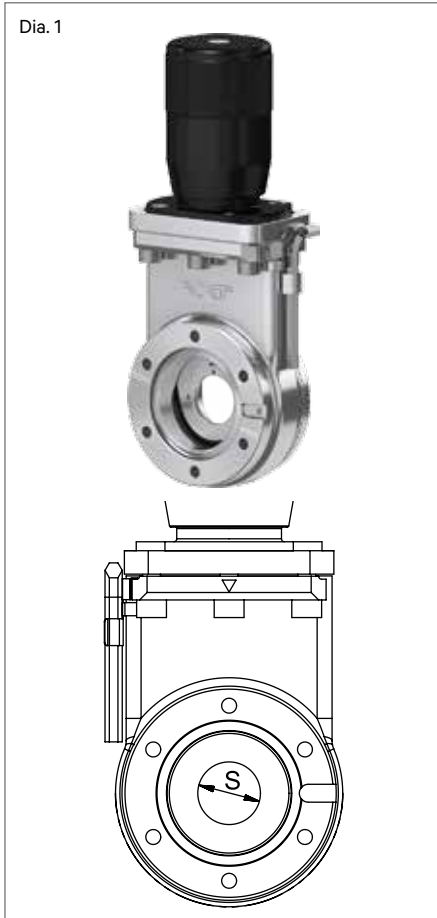

		Window screwed into gate. Window material: e. g. borosilicate Seals: elastomer			
		1 Valve body 2 Gate 3 Elastomer seal 4 Window 5 Screwed window retainer ▼ Valve seat side			
DN valve	mm inch	16 5/8	25 1	40 1½	50 2
Optically free diameter «S»	mm inch	21 0.82	21 0.82	21 0.82	21 0.82
Thickness of glass	mm inch	1.5 0.06	1.5 0.06	1.5 0.06	1.5 0.06

## MODULAR DESIGN

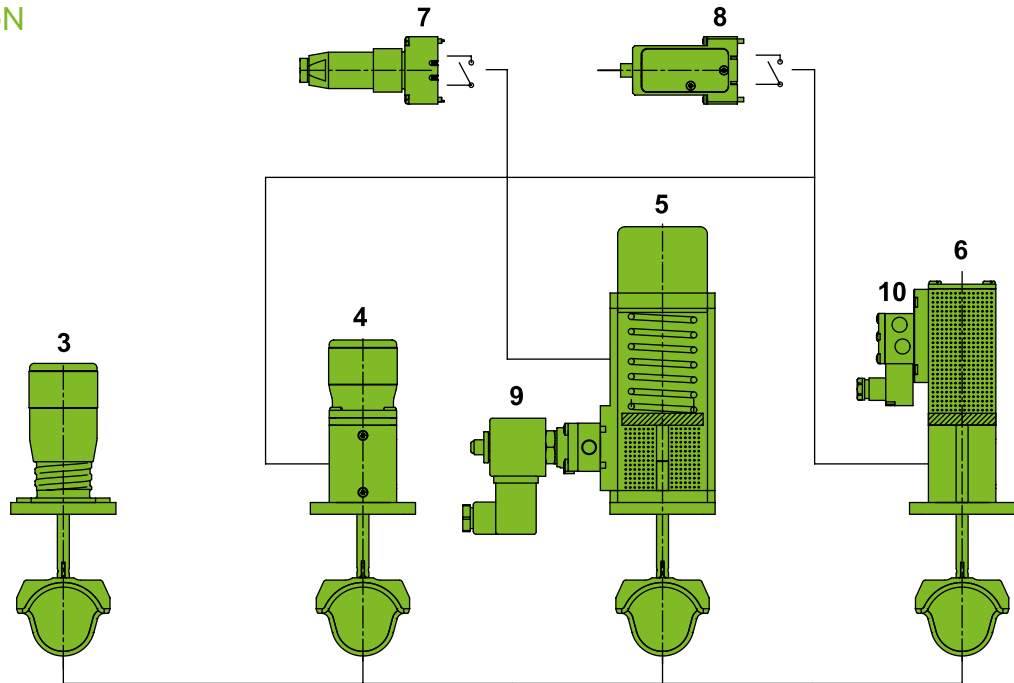

- 1 Valve body with CF-F flange
- 2 Valve body with ISO-KF flange
- 3 Manual actuator
- 4 Manual actuator with position indicator
- 5 Pneumatic actuator: single acting with closing spring (NC) or single acting with opening spring (NO)
- 6 Pneumatic actuator: double acting, mechanically locked
- 7 Position indicator for 80 °C (standard)
- 8 Position indicator for 200 °C (option)
- 9 3/2-way solenoid valve
- 10 4/2-way solenoid valve

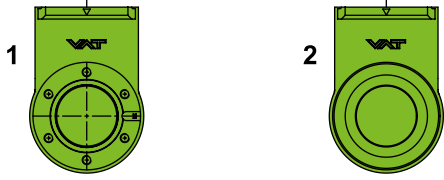

## SPECIAL VERSIONS FOR GAS ANALYSIS

Pressure reduction of the process gas by means of two by-pass valves with orifice.



Vacuum-tight valve with manual or pneumatic actuator.

Bypass valves with manual or pneumatic actuator and application specific, easily exchangeable orifice.

Pressure reduction of the process gas by means of maximum 3 gate valves with orifice.



Vacuum-tight valve with manual or pneumatic actuator.

One to three gate valves, each rotated by 90°, with manual or pneumatic actuator and application specific, easily exchangeable orifice.

For details see pages 336 + 337.

## SPARE PARTS

We can offer a wide variety of spare parts. Please contact us for details and an offer.

Thank you for specifying the fabrication number of the valve indicated on the identification tag when asking for spare parts.

## ACCESSORIES

Flange connections for installation of the valve: see series 31 and 33

## ORDERING INFORMATION FOR STANDARD VALVES

**Valve with manual actuator**  
turning handle

DN		Ordering numbers		
mm	inch	ISO-KF	CF-F metric threads	CF-F UNF threads
16	¾	01024-KE01	-	-
25	1	01028-KE01	-	-
40	1½	01032-KE01	01032-CE01	01032-UE01
50	2	01034-KE01	-	-

with position indicator: 010 . . . E08

**Valve with pneumatic actuator**  
single acting with closing spring (NC)  
without solenoid valve  
without position indicator

DN		Ordering numbers		
mm	inch	ISO-KF	CF-F metric threads	CF-F UNF threads
16	¾	01024-KE11	-	-
25	1	01028-KE11	-	-
40	1½	01032-KE11	01032-CE11	01032-UE11
50	2	01034-KE11	-	-

without solenoid valve, with position indicator: 010 . . . E21

with solenoid valve, with position indicator: 010 . . . E41 (specify control voltage)

**Valve with pneumatic actuator**  
single acting with opening spring (NO)  
without solenoid valve  
without position indicator

DN		Ordering numbers		
mm	inch	ISO-KF	CF-F metric threads	CF-F UNF threads
16	¾	01024-KE12	-	-
25	1	01028-KE12	-	-
40	1½	01032-KE12	01032-CE12	01032-UE12
50	2	01034-KE12	-	-

without solenoid valve, with position indicator: 010 . . . E22

with solenoid valve, with position indicator: 010 . . . E42 (specify control voltage)

**Valve with pneumatic actuator**  
double acting  
without solenoid valve  
without position indicator

DN		Ordering numbers		
mm	inch	ISO-KF	CF-F metric threads	CF-F UNF threads
16	¾	01024-KE14	-	-
25	1	01028-KE14	-	-
40	1½	01032-KE14	01032-CE14	01032-UE14
50	2	01034-KE14	-	-

without solenoid valve, with position indicator: 010 . . . E24

with solenoid valve, with position indicator: 010 . . . E44 (specify control voltage)

## ORDERING INFORMATION FOR VALVES WITH OPTIONS

Basic ordering number plus «-X»: -X to be specified

Example: 01032-CE44-X, X = special bellows for 1 million cycles

DIMENSIONS

A

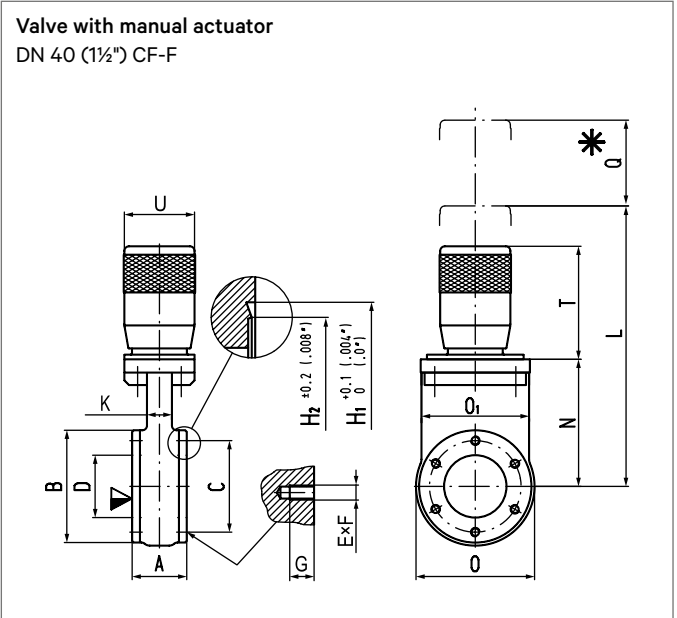
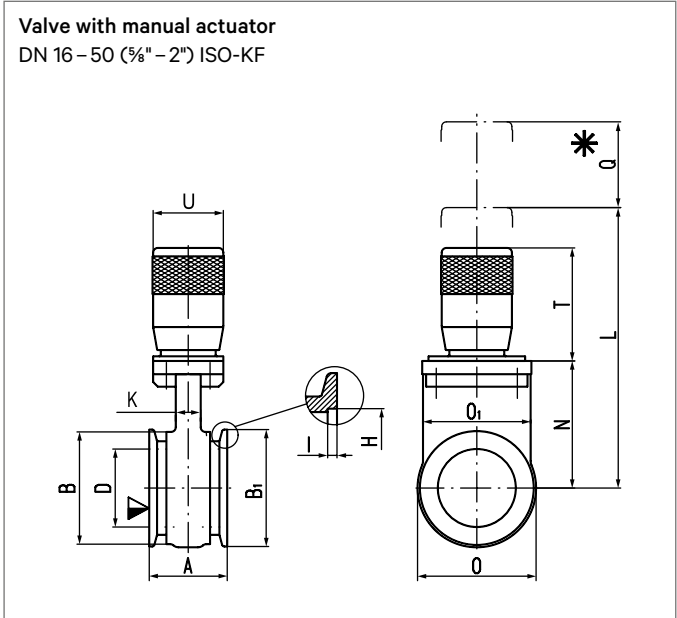

- ▼ Valve seat side
- \* Required for dismantling

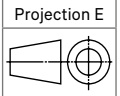

DN	mm inch	16 ¾	25 1	40 1½	50 (ID 40) 2 (ID 1.57)
A	mm inch	50 1.97	50 1.97	50 1.97	50 1.97
B	mm inch	71.80 2.83	71.80 2.83	71.80 2.83	71.80 2.83
B1	mm inch	29.90 1.18	39.90 1.57	54.90 2.16	74.90 2.95
D	mm inch	16.10 0.63	25.10 0.99	40.10 1.58	40.10 1.58
H	mm inch	17.30 0.68	26.30 1.04	41.30 1.63	52.30 2.06
I	mm inch	3 0.12	3 0.12	3 0.12	3 0.12
K	mm inch	16 0.63	16 0.63	16 0.63	16 0.63
L	mm inch	197.80 7.79	197.80 7.79	197.80 7.79	197.80 7.79
N	mm inch	81.30 3.20	81.30 3.20	81.30 3.20	81.30 3.20
O	mm inch	76.20 3	76.20 3	76.20 3	76.20 3
O1	mm inch	70.20 2.76	70.20 2.76	70.20 2.76	70.20 2.76
Q	mm inch	55 2.17	55 2.17	55 2.17	55 2.17
T	mm inch	73.50 2.89	73.50 2.89	73.50 2.89	73.50 2.89
U	mm inch	45.80 1.80	45.80 1.80	45.80 1.80	45.80 1.80

DN	mm inch	40 1½			
A	mm inch	35 1.38			
B	mm inch	71.80 2.83			
C	mm inch	58.70 2.31			
D	mm inch	40.10 1.58			
E x F		6 x M6 6 x ¼"-28 UNF			
G	mm inch	7 0.28			
H1	mm inch	48.35 1.90			
H2	mm inch	42 1.65			
K	mm inch	16 0.63			
L	mm inch	197.80 7.79			
N	mm inch	81.30 3.20			
O	mm inch	76.20 3			
O1	mm inch	70.20 2.76			
Q	mm inch	55 2.17			
T	mm inch	73.50 2.89			
U	mm inch	45.80 1.80			

## DIMENSIONS

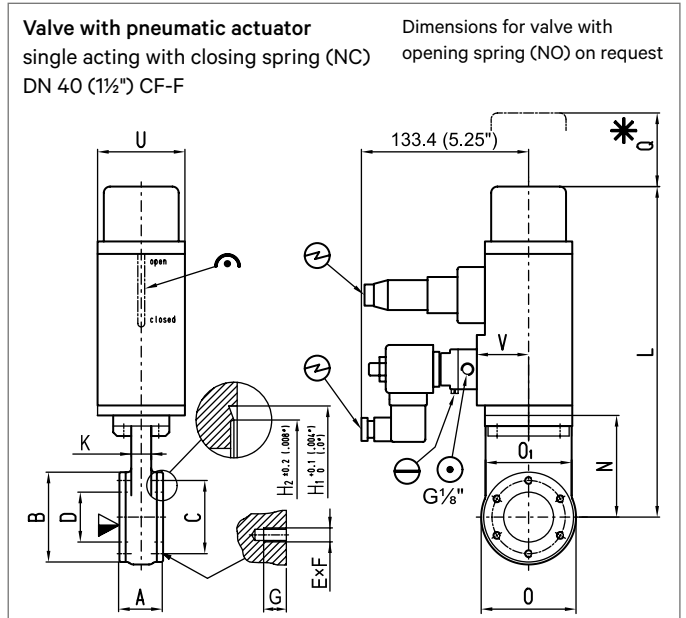
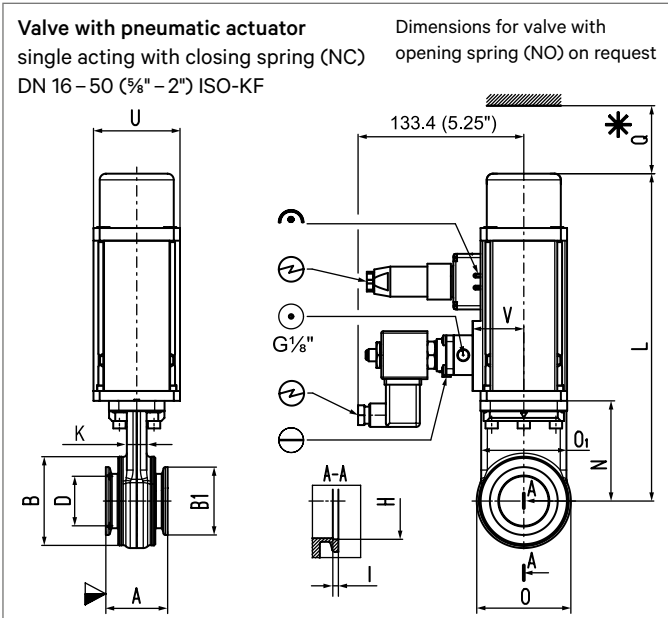

- ▼ Valve seat side
- \* Required for dismantling
- ⊙ Compressed air connection
- ⊖ Electrical connection
- ⤴ Mechanical position indication
- ⊖ Emergency operation

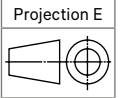

DN	mm inch	16 ¾"	25 1"	40 1½"	50 (ID 40) 2 (ID 1.57)
A	mm inch	50 1.97	50 1.97	50 1.97	50 1.97
B	mm inch	71.80 2.83	71.80 2.83	71.80 2.83	71.80 2.83
B1	mm inch	29.90 1.18	39.90 1.57	54.90 2.16	74.90 2.95
D	mm inch	16.10 0.63	25.10 0.99	40.10 1.58	40.10 1.58
H	mm inch	17.30 0.68	26.30 1.04	41.30 1.63	52.30 2.06
I	mm inch	3 0.12	3 0.12	3 0.12	3 0.12
K	mm inch	16 0.63	16 0.63	16 0.63	16 0.63
L	mm inch	265.50 10.45	265.50 10.45	265.50 10.45	265.50 10.45
N	mm inch	81.30 3.20	81.30 3.20	81.30 3.20	81.30 3.20
O	mm inch	76.20 3	76.20 3	76.20 3	76.20 3
O1	mm inch	70.20 2.76	70.20 2.76	70.20 2.76	70.20 2.76
Q	mm inch	55 2.17	55 2.17	55 2.17	55 2.17
U	mm inch	70 2.75	70 2.75	70 2.75	70 2.75
V	mm inch	41.50 1.63	41.50 1.63	41.50 1.63	41.50 1.63

DN	mm inch	40 1½"			
A	mm inch	35 1.38			
B	mm inch	71.80 2.83			
C	mm inch	58.70 2.31			
D	mm inch	40.10 1.58			
E × F		6 × M6 6 × ¼"-28 UNF			
G	mm inch	7 0.28			
H1	mm inch	48.35 1.90			
H2	mm inch	42 1.65			
K	mm inch	16 0.63			
L	mm inch	265.50 10.45			
N	mm inch	81.30 3.20			
O	mm inch	76.20 3			
O1	mm inch	70.20 2.76			
Q	mm inch	55 2.17			
U	mm inch	70 2.75			
V	mm inch	41.50 1.63			

## DIMENSIONS

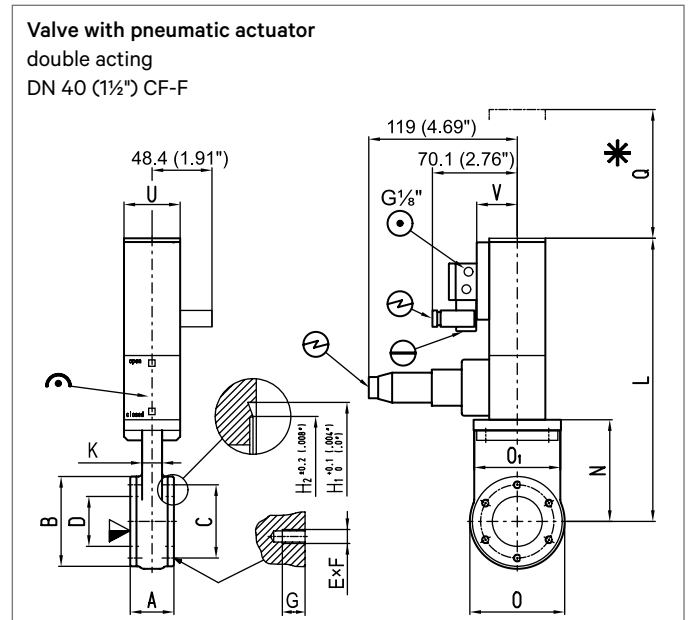
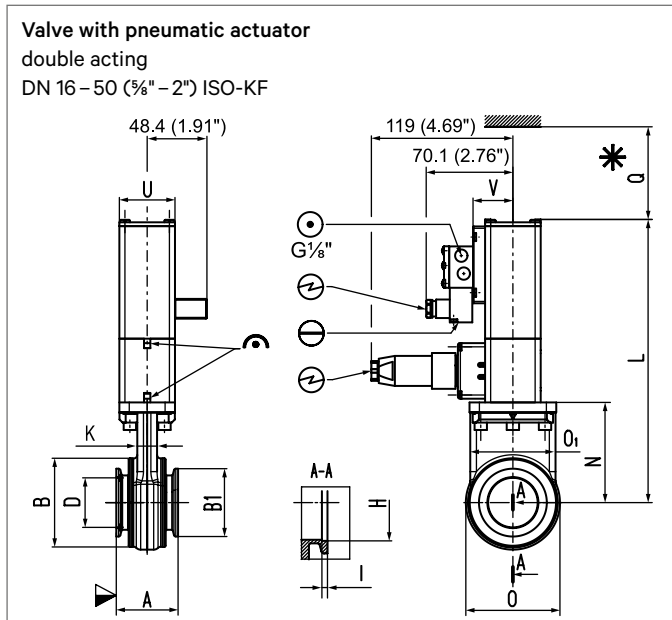

- ▼ Valve seat side
- \* Required for dismantling
- ⊙ Compressed air connection
- ⊕ Electrical connection
- ⌒ Mechanical position indication
- ⊖ Emergency operation

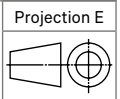

DN	mm inch	16 ¾"	25 1"	40 1½"	50 (ID 40) 2 (ID 1.57)
A	mm inch	50 1.97	50 1.97	50 1.97	50 1.97
B	mm inch	71.80 2.83	71.80 2.83	71.80 2.83	71.80 2.83
B1	mm inch	29.90 1.18	39.90 1.57	54.90 2.16	74.90 2.95
D	mm inch	16.10 0.63	25.10 0.99	40.10 1.58	40.10 1.58
H	mm inch	17.30 0.68	26.30 1.04	41.30 1.63	52.30 2.06
I	mm inch	3 0.12	3 0.12	3 0.12	3 0.12
K	mm inch	16 0.63	16 0.63	16 0.63	16 0.63
L	mm inch	229.10 9.02	229.10 9.02	229.10 9.02	229.10 9.02
N	mm inch	81.30 3.20	81.30 3.20	81.30 3.20	81.30 3.20
O	mm inch	76.20 3	76.20 3	76.20 3	76.20 3
O1	mm inch	70.20 2.76	70.20 2.76	70.20 2.76	70.20 2.76
Q	mm inch	55 2.17	55 2.17	55 2.17	55 2.17
U	mm inch	45 1.77	45 1.77	45 1.77	45 1.77
V	mm inch	32.30 1.27	32.30 1.27	32.30 1.27	32.30 1.27

DN	mm inch	40 1½"			
A	mm inch	35 1.38			
B	mm inch	71.80 2.83			
C	mm inch	58.70 2.31			
D	mm inch	40.10 1.58			
E × F		6 × M6 6 × ¼"-28 UNF			
G	mm inch	7 0.28			
H1	mm inch	48.35 1.90			
H2	mm inch	42 1.65			
K	mm inch	16 0.63			
L	mm inch	229.10 9.02			
N	mm inch	81.30 3.20			
O	mm inch	76.20 3			
O1	mm inch	70.20 2.76			
Q	mm inch	55 2.16			
U	mm inch	45 1.77			
V	mm inch	32.30 1.27			