

Control and isolation valve

General purpose stainless steel valve

Adaptive pressure control with stepper motor or throttling by adjustable 3-position pneumatic actuator



Body material

stainless steel

Throttling gate valve with 3-position pneumatic actuator

double acting with position indicator with solenoids

DN		Ordering numbers (specify control voltage)				
mm	inch	ISO-F	CF-F metric threads	CF-F UNF threads	ASA-LP (T) ASA (A)	JIS
100	4	64040-PE48	64040-CE48	64040-UE48	64040-TE48	64040-JE48
160	6	64044-PE48	64044-CE48	64044-UE48	64044-TE48	64044-JE48
200	8	64046-PE48	64046-CE48	64046-UE48	64046-TE48	64046-JE48
250	10	64048-PE48	64048-CE48	64048-UE48	64048-TE48	64048-JE48
320	12	64050-PE48	on request	on request	64050-TE48	64050-JE48
350	12	–	–	–	–	64051-JE48
400	16	64052-PE48	on request	on request	64052-AE48	64052-JE48

with position indicator, without solenoids: 640 . . . E28

Control gate valve with stepper motor

100	4	64040-PE52	64040-CE52	64040-UE52	64040-TE52	64040-JE52
160	6	64244-PE52	64244-CE52	64244-UE52	64244-TE52	64244-JE52
200	8	64246-PE52	64246-CE52	64246-UE52	64246-TE52	64246-JE52
250	10	64248-PE52	64248-CE52	64248-UE52	64248-TE52	64248-JE52
320	12	64250-PE52	on request	on request	64250-TE52	64250-JE52
350	12	–	–	–	–	64251-JE52
400	16	64252-PE52	on request	on request	64252-AE52	64252-JE52

Pressure controller

Type		Ordering numbers	Interface	Sensor(s)
PM-5	local and remote control	641PM-16xy	A = without	1
PM-4	remote control with service box interface	641PM-26xy	B = without	2
			C = logic	1
			E = logic	2
			G = RS232	1
			H = RS232	2
			J = RS485	1
			K = RS485	2

PFO = Power Failure Option (valve closes at power failure)

A = without PFO
B = NiCd PFO

Connection cable

Control gate valve — pressure controller	Ordering numbers
length 3 m (10 ft)	640CV-99LC
length 10 m (33 ft)	640CV-99LJ
other lengths to max. 50 m (170 ft)	640CV-99LX *)

*) specify length X in m/ft

Sealing materials

Gate: VITON

Bonnet: VITON

Feedthrough

Rotary feedthrough / VITON

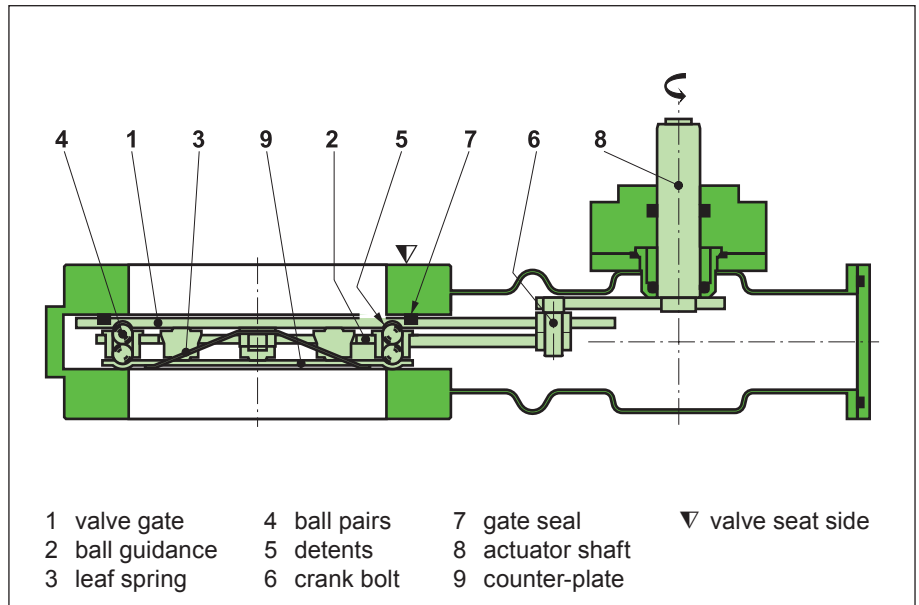

B

Features

VATLOCK configuration

3-position pneumatic actuator or stepper motor

Function

The valve gate acts as a throttling element and varies the conductance of the valve opening. Actuation is performed either with a 3-position pneumatic actuator or with a stepper motor and controller. With the 3-position pneumatic actuator, it is not only possible to move the valve gate to the open and closed position, but also to any preset intermediate position. The stepper motor/controller version ensures accurate pressure control due to exact gate positioning. For leaktight closing the VATLOCK principle is applied. For details see page 201.

Control range

VAT has a software «Valve Evaluation Tool» to determine the most suitable product for a specific application. Please contact us to assist you when selecting a product.

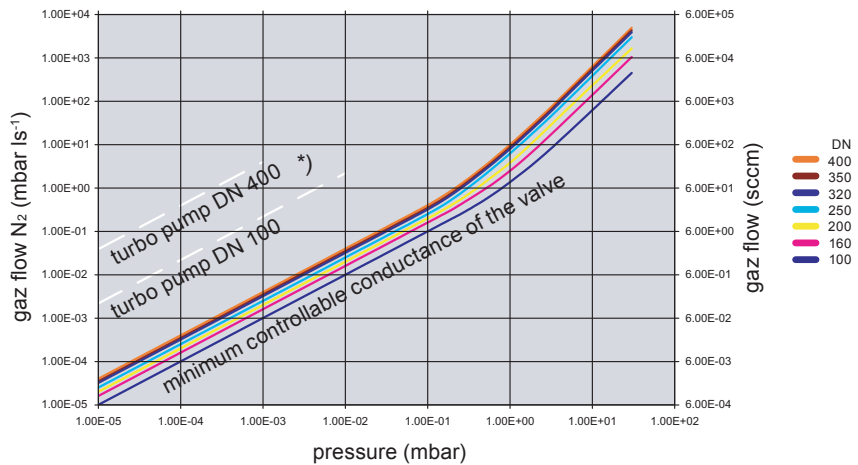

*) approx. upper pressure limit (depending on pump size, pump type and customer system)

Valve types

- 1) Control gate valve with stepper motor DN 160 - 400
- 2) Control gate valve with stepper motor DN 100
- 3) Control gate valve with adjustable 3-position pneumatics DN 100 - 400



Technical data

Leak rate: body, valve seat	< 1 · 10 ⁻⁹ mbar ls ⁻¹
Pressure range	
- DN 100 - 200	1 · 10 ⁻⁸ mbar to 2 bar (abs)
- DN 250 - 400	1 · 10 ⁻⁸ mbar to 1.2 bar (abs)
Differential pressure	
- Valve closed	DN 100 - 200 ≤ 2 bar in either direction DN 250 - 400 ≤ 1.2 bar in either direction
- During opening / closing	≤ 30 mbar
Cycles until first service	200000
Operating temperature ¹⁾	
- Valve body	10°C - 150°C
Ambient temperature ¹⁾	
- Pneumatic actuator, motor	≤ 50 °C
- Position indicator	≤ 80 °C
- Solenoid	≤ 50 °C
Material	
- Valve body, gate	AISI 304 (1.4301)
- Mechanism	AISI 300 and 400 series (1.4301, 1.4310, 1.4034, 1.4016, 1.4037)
Mounting position	
- DN 100 - 350	any
- DN 400	horizontal only (vertical mounting position: see «Options»)
Valve position	visual (mechanical and on controller)
Connections actuator	
- 3-position pneumatic actuator	compressed air (see table below)
- Solenoids	24 V DC, 2 x 2.5 W (others see «options»)
- Position indicator: contact rating	
- Voltage	≤ 30 VAC/DC
- Current	≤ 0.3A
- Power	≤ 9W
- Stepper motor	VAT Pressure Controller

¹⁾ Maximum values: depending on operating conditions and sealing materials

DN (nominal I. D.)		standard flanges				molecular flow conductance	stepper motor				3-position pneumatic actuator					
		CF-F	ISO-F	ASA-LP	JIS		minimum controllable conductance	minimum closing or opening time	weight		minimum adjustable conductance	compressed air pressure min. - max. overpressure		closing or opening time	weight	
mm	inch	O.D.				ls ⁻¹	ls ⁻¹	s	kg	lbs	ls ⁻¹	bar	psi	s	kg	lbs
100	4	6	100	3	100	1700	1	3	17	37	5	4 - 7	55 - 100	2.5	17	37
160	6	8	160	4	150	5000	1.6	6	28	62	7.5	4 - 7	55 - 100	3.5	30	66
200	8	10	200	6	200	12000	2	6	34	75	10	4 - 7	55 - 100	3.5	36	79
250	10	12	250	8	250	22000	2.5	10	62	136	12.5	4 - 7	55 - 100	6	69	151
320	12		320	10	300	30000	3.2	10	112	246	16	4 - 7	55 - 100	6	119	261
350	14	-	-	-	350	40000	3.5	10	120	264	16	4 - 7	55 - 100	6	127	279
400	16		400	14	400	50000	4	10	155	340	20	4 - 7	55 - 100	10	164	360

Options

Certain options are not available for some nominal diameters or cannot be combined. Moreover, options can affect the general technical data.

Diagram 1

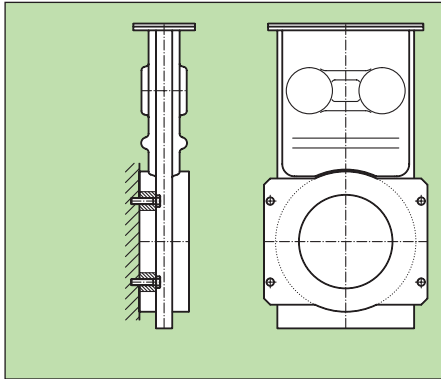
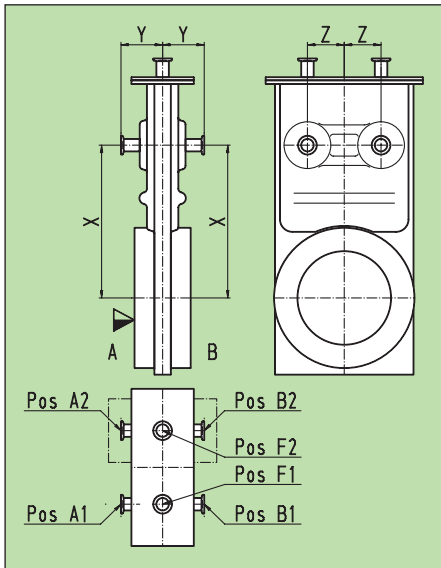

Diagram 2



▽ valve seat side

Actuator:

- Actuator rotated by 90° / 180° to position 2 or 3 (position 1 is standard): see dimensional drawings on pages 88 and 89 for optimum adaptation
- Actuator on B-side (A-side is standard)
- Stepper motor for vertical mounting position DN 400 (closing time 15 s, cycles until first service 50 000)
- Solenoids for impulse actuation: actual valve position is maintained at power failure
- Solenoid separate, for external mounting
- Solenoid for 12, 48 V DC
24, 48, 100, 115, 200, 220 V / 50 Hz
24, 100, 115, 200, 220 V / 60 Hz

Valve:

- Sizes DN 63 and 80 on request
- Customer specified flanges
- For direct mounting to flat chamber (diagram 1) Special flange for mounting to chamber wall, standard flange on opposite side
- Other sealing materials
- Watercooled or waterheated flanges (ISO-F)
- Rotary feedthrough with pump port
- Ports (diagram 2) for roughing (by-pass), venting or for gauges

DN valve	mm inch	100 4	160 6	200 8	250 10	320 12	350 14	400 16
recommended port	CF-F ISO-KF	40	40	40	40	40	40	40
X	mm inch	185 7.28	245 9.65	304.4 11.98	387.3 15.25	482 18.98	482 18.98	415 16.34
Y	mm inch	56 2.2	67 2.64	67 2.64	89 3.5	72 2.89	72 2.89	77 3.03
Z	mm inch	47.5 1.87	59 2.32	85 3.35	100 3.94	135 5.31	135 5.31	140 5.51

Ordering information for options:

Ordering No. of valve-X

(e. g. 64244-CE52-X, X = actuator A2, port KF40 in position B2)

Heater

Thermostat temperature control 80°C, 100°C, 120°C
or temperature sensor for external control (PT100 or thermocouple)
Supply voltage: 100 - 120 V resp. 200 - 240 V AC
Insulation box for touch protection

Accessories

Fittings for installation of the valve: series 32 and 33

Seal kit

Consisting of seals for gate, bonnet and rotary feedthrough
Ordering No.: see operating manual or price list

Stepper motor

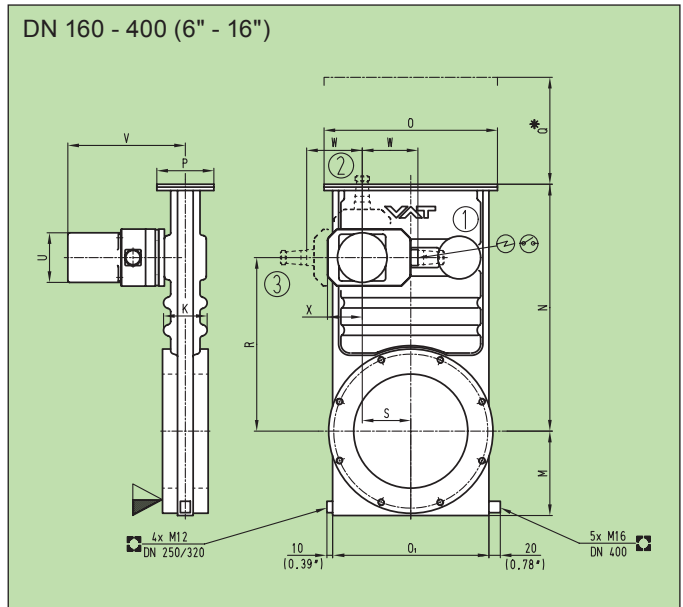
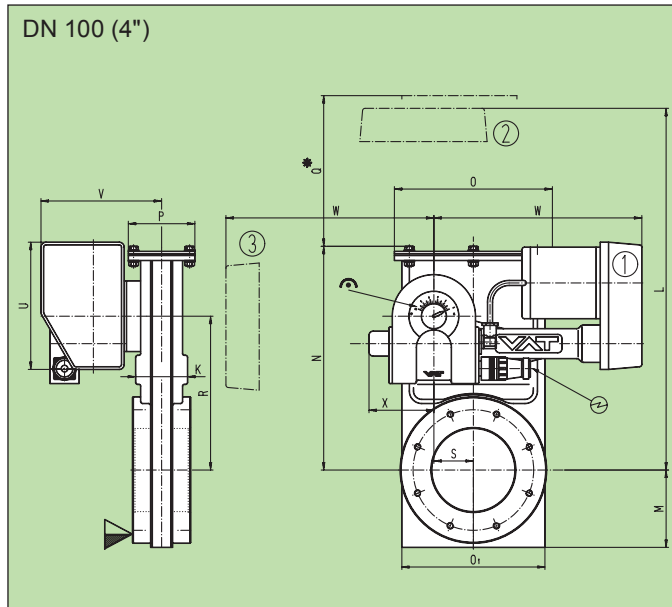

- ▼ valve seat side
- * required for dismantling
- ⊙ compressed air connection
- ⌚ mechanical position indication
- for attachment
- ⊕ electrical connection

- ① standard actuator position (A1)
- ② ③ optional actuator positions

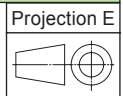

DN	mm inch	100 4	160 6	200 8	250 10	320 12	350 14	400 16
K	mm inch	63 2.48	75 2.95	77 3.03	116 4.57	120 4.72	120 4.72	130 5.12
L	mm inch	435 17.12						
M	mm inch	93 3.66	123 4.84	148 5.83	177 6.97	214 8.43	214 8.43	232 9.13
N	mm inch	270 10.63	362 14.25	442 17.4	570 22.44	689 27.13	689 27.13	790 31.1
O	mm inch	190 7.48	252 9.92	304 11.97	400 15.75	475 18.7	475 18.7	520 20.47
O1	mm inch	172 6.77	222 8.74	274 10.79	356 14.02	421 16.57	421 16.57	474 18.66
P	mm inch	80 3.15	100 3.94	100 3.94	138 5.43	138 5.43	138 5.43	138 5.43
Q	mm inch	220 8.66	300 11.81	350 13.78	450 17.72	550 21.65	550 21.65	600 23.62
R	mm inch	185 7.28	245 9.65	304.4 11.98	387.3 15.25	482 18.98	482 18.98	568 22.36
S	mm inch	47.5 1.87	59 2.32	85 3.35	100 3.94	135 5.31	135 5.31	140 5.51
U	mm inch	153 6.02	87 3.43	87 3.43	87 3.43	87 3.43	87 3.43	87 3.43
V	mm inch	142 5.59	207 8.1	207 8.1	248 9.76	248 9.76	248 9.76	253 9.96
W	mm inch	250 9.84	98.5 3.88	98.5 3.88	118.5 4.67	118.5 4.67	118.5 4.67	118.5 4.67
X	mm inch	78 3.07	61 2.4	61 2.4	74 2.91	74 2.91	74 2.91	74 2.91

3-position pneumatic actuator

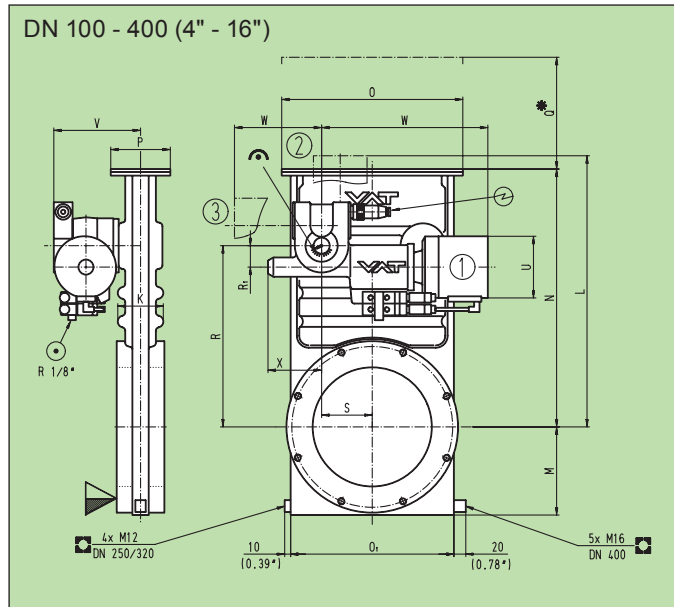

- ▽ valve seat side
- * required for dismantling
- ⊕ compressed air connection
- ⊖ electrical connection
- ⌚ mechanical position indication
- for attachment
- ① standard actuator position (A1)
- ② ③ optional actuator positions

¹⁾ L + W, DN 100: without pneumatic connection 6 mm shorter

DN	mm inch	100 4	160 6	200 8	250 10	320 12	350 14	400 16
K	mm inch	63 2.48	75 2.95	77 3.03	116 4.57	120 4.72	120 4.72	130 5.12
L	mm inch	503 ¹⁾ 19.8	569 22.4	628 24.72	843 33.19	938 36.93	938 36.93	1024 40.31
M	mm inch	93 3.66	123 4.84	148 5.83	177 6.97	214 8.43	214 8.43	232 9.13
N	mm inch	270 10.63	362 14.25	442 17.4	570 22.44	689 27.13	689 27.13	790 31.1
O	mm inch	190 7.48	252 9.92	304 11.97	400 15.75	475 18.7	475 18.7	520 20.47
O1	mm inch	172 6.77	222 8.74	274 10.79	356 14.02	421 16.57	421 16.57	474 18.66
P	mm inch	80 3.15	100 3.94	100 3.94	138 5.43	138 5.43	138 5.43	138 5.43
Q	mm inch	220 8.66	300 11.81	350 13.78	450 17.72	550 21.65	550 21.65	600 23.62
R	mm inch	185 7.28	245 9.65	304.4 11.98	387.3 15.25	482 18.98	482 18.98	568 22.36
R1	mm inch	33 1.3	40 1.57	40 1.57	50 1.97	50 1.97	50 1.97	50 1.97
S	mm inch	47.5 1.87	59 2.32	85 3.35	100 3.94	135 5.31	135 5.31	140 5.51
U	mm inch	96 3.78	115 4.53	115 4.53	165 6.5	165 6.5	165 6.5	165 6.5
V	mm inch	158 6.22	159 6.26	159 6.26	216.5 8.52	216.5 8.52	216.5 8.52	221.5 8.72
W	mm inch	318 ¹⁾ 12.52	324 12.76	324 12.76	456 17.95	456 17.95	456 17.95	456 17.95
X	mm inch	78 3.07	101 3.98	101 3.98	131 5.16	131 5.16	131 5.16	131 5.16

Flange dimensions

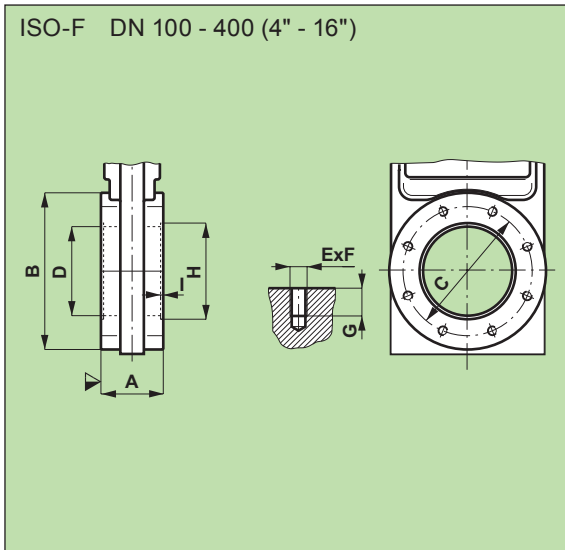

DN	mm inch	100 4	160 6	200 8	250 10	320 12	400 16
A	mm inch	70 2.76	80 3.15	80 3.15	100 3.94	120 4.72	150 5.9
B	mm inch	176 6.93	225 8.86	288 11.34	350 13.78	425 16.73	510 20.08
C	mm inch	145 5.71	200 7.87	260 10.24	310 12.2	395 15.55	480 18.9
D	mm inch	100 3.94	150 5.91	200 7.87	261 10.28	318 12.52	400 15.75
E x F		8 x M8	8 x M10	12 x M10	12 x M10	12 x M12	16 x M12
G	mm inch	13 0.51	14 0.55	16 0.63	16 0.63	16 0.63	20 0.79
H	mm inch	102 4.02	153 6.02	213 8.39	-	-	-
I	mm inch	3 0.12	5 0.2	5 0.2	-	-	-

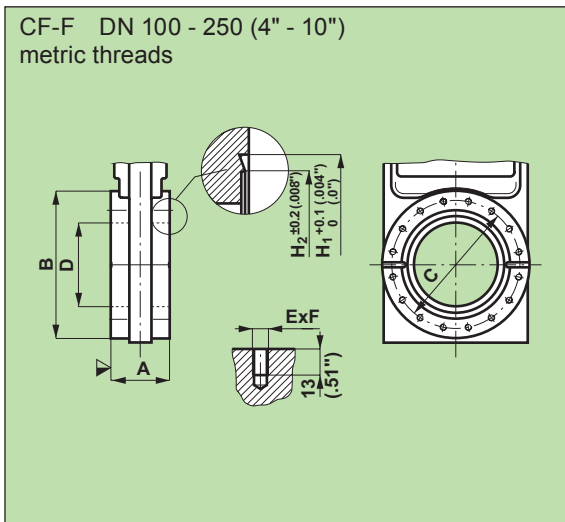

DN	mm inch	100 4	160 6	200 8	250 10		
O.D.	inch	6	8	10	12		
A	mm inch	70 2.76	80 3.15	80 3.15	100 3.94		
B	mm inch	176 6.93	225 8.86	288 11.34	350 13.78		
C	mm inch	130.2 5.13	181 7.13	231.8 9.13	284 11.18		
D	mm inch	100 3.94	150 5.91	200 7.87	254 10		
E x F		16 x M8	20 x M8	24 x M8	32 x M8		
H1	mm inch	120.65 4.75	171.45 6.75	222.3 8.75	273.15 10.75		
H2	mm inch	115.5 4.55	166 6.54	217 8.54	267 10.51		

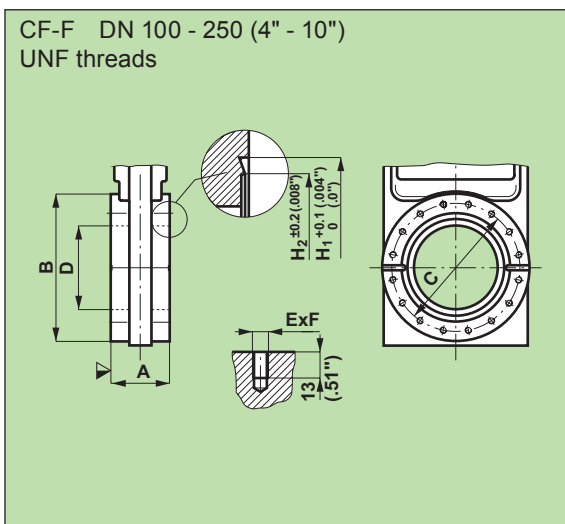

DN	mm inch	100 4	160 6	200 8	250 ¹⁾ 10	250 ¹⁾ 10	
O.D.	inch	6	8	10	12	13 1/4	
A	mm inch	70 2.76	80 3.15	80 3.15	100 3.94	100 3.94	
B	mm inch	176 6.93	225 8.86	288 11.34	350 13.78	350 13.78	
C	mm inch	130.2 5.13	181 7.13	231.8 9.13	284 11.18	306.3 12.06	
D	mm inch	100 3.94	150 5.91	200 7.87	254 10	254 10	
E x F		16 x 5/16" 24 UNF	20 x 5/16" 24 UNF	24 x 5/16" 24 UNF	32 x 5/16" 24 UNF	30 x 3/8" 24 UNF	
H1	mm inch	120.65 4.75	171.45 6.75	222.3 8.75	273.15 10.75	294.64 11.6	
H2	mm inch	115.5 4.55	166 6.54	217 8.54	267 10.51	288.3 11.35	

¹⁾ O.D. 12" VAT standard, O.D. 13 1/4" option

Ordering information for option: O.D. 13 1/4"

Ordering No. of valve-X (e. g. 64048-UE48-X, X = O.D. 13 1/4")

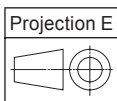

▽ valve seat side

Flange dimensions

ASA-LP DN 100 - 400 (4" - 16")
with or without O-ring groove

For orders **with** O-ring groove specify:
«A», «B» or «A + B»

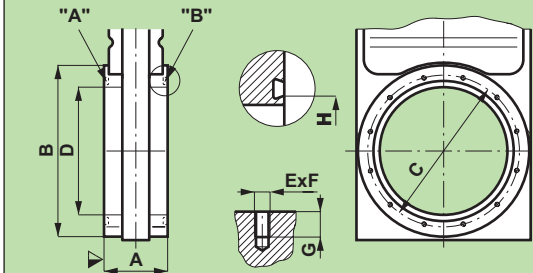

DN	mm inch	100 4	160 6	200 8	250 10	320 12	400 16
ASA-LP		3	4	6	8	10	16 ¹⁾
A	mm inch	70 2.76	80 3.15	80 3.15	100 3.94	120 4.72	150 5.9
B	mm inch	176 6.93	225 8.86	288 11.34	350 13.78	425 16.73	596.9 23.5
C	mm inch	152.4 6	190.5 7.5	241.3 9.5	298.5 11.75	362 14.25	539.8 21.25
D	mm inch	100 3.94	150 5.91	200 7.87	254 10	300 11.81	400 15.75
E x F		4 x 3/8" 16 UNC	8 x 3/8" 16 UNC	8 x 3/4" 10 UNC	8 x 3/4" 10 UNC	12 x 3/4" 10 UNC	16 x 1" 8 UNF
G	mm inch	15 0.59	15 0.59	20 0.79	20 0.79	28 1.1	25.4 1
H	mm inch	120.65 4.75	158.75 6.25	206.4 8.13	266.7 10.5	317.5 12.5	419.1 16.5
O-Ring I.D. x d		120.24 x 3.53 4.73 x .139	158.34 x 3.53 6.23 x .139	202.79 x 3.53 7.98 x .139	266.29 x 3.53 10.48 x .139	316.87 x 7.00 12.47 x .275	417.96 x 7.00 16.46 x .275

¹⁾ ASA

JIS DN 100 - 400 (4" - 16")

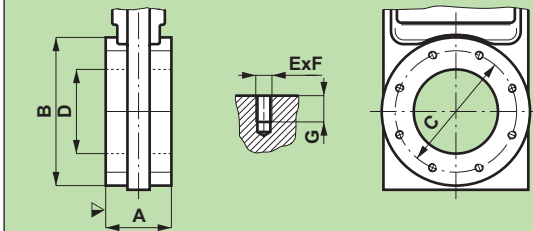

DN	mm inch	100 4	150 6	200 8	250 10	300 12	350 14	400 16
A	mm inch	70 2.76	80 3.15	80 3.15	100 3.94	120 4.72	120 4.72	150 5.9
B	mm inch	176 6.93	225 8.86	288 11.34	350 13.78	425 16.73	450 17.72	510 20.08
C	mm inch	160 6.3	210 8.27	270 10.63	320 12.6	370 14.57	420 16.54	480 18.9
D	mm inch	100 3.94	150 5.91	200 7.87	261 10.28	318 12.52	350 13.78	400 15.75
E x F		8 x M10	8 x M10	8 x M12	12 x M12	12 x M12	12 x M12	12 x M16
G	mm inch	12 0.47	14 0.55	16 0.63	16 0.63	16 0.63	16 0.63	25 0.98

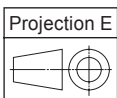

▽ valve seat side

Pressure controller



PM-5: Version for local and remote control
 PM-4: Version for remote control



Features	PM-4	PM-5
Fast and accurate adaptive pressure control	X	X
Automatic learning of system parameters	X	X
Hold function for plasma ignition	X	X
Position control	X	X
Local operation		X
Interface for service box	X	
Operation with remote control interface	X	X ¹⁾
Large information display		X
LED function indicators	X	
Interface for linear pressure sensors (capacitance manometers)	X	X
Zero adjust of sensor	X	X
Closing of valve at power failure (option)	X ¹⁾	X ¹⁾

¹⁾ Option

Pressure control

The PM-4 / PM-5 controllers ensure fast and accurate pressure control. The LEARN function, being performed only once during system set-up, automatically determines all relevant system parameters.

During pressure control the pressure controller continuously adapts to the process conditions (gas type, gas flow). No parameter inputs are necessary.

Position control

The PM-4 / PM-5 controllers are provided with a position control mode that allows to control any valve position between 'open – closed' with selectable speed.

Local operation

The PM-5 controller can be operated locally via keyboard and display on the front panel. In combination with a service box the PM-4 controller can also be operated locally.

Display

The PM-5 controller has a large display for pressure, position and status information. The pressure can be displayed in various ranges (0-1, 2.5, 5, 10, 20 1000) and units (mbar, µbar, kPa, Pa, Torr, mTorr).

Remote operation

By means of a remote control interface the controllers PM-4 / PM-5 can be controlled by a host system (see selectable interface options below).

Logic interface

- | | |
|-----------------|---|
| Digital inputs | <ul style="list-style-type: none"> - opening and closing of valve - control mode and setpoint selection - LEARN, zero adjust, and hold - keyboard interlock |
| Digital outputs | <ul style="list-style-type: none"> - valve position open and closed - remote control status - setpoint deviation |
| Analog inputs | <ul style="list-style-type: none"> - pressure and position setpoints |
| Analog outputs | <ul style="list-style-type: none"> - current pressure and valve position |

RS232 interface	Serial RS232 interface	- operation of all functions, selectable baudrate (110 - 19200)
	Digital inputs	- opening and closing of valve
	Digital outputs	- valve position open and closed
Power Failure Option	This function is available as an option. It automatically closes the valve at power failure.	
Technical data	Mains voltage	100 - 240V (± 10 %), 50/60 Hz
	Power required	max. 150W
	Ambient temperature	0 - 50°C
	Pressure control accuracy	0.1 % of the sensor full scale range
	Position control	1000 positions
	Pressure sensor	
	- Sensor input voltage	0 - 1V, 2V, 5V, 10V (selectable)
	- Sensor input	differential, R _i > 100 kOhm
	- Sensor power supply	+ 15 V (± 5 %), max. 1400 mA *) - 15 V (± 5 %), max. 1400 mA *) *) total for both sensors with 2-sensor version
	Power Failure Option (PFO)	
	- Akku type	NiCd
	- Minimum charge time	10 h
	- Life time (35°C)	20 months
Inputs (interface option)		
- Digital	control with relay contacts or optocouplers	
- Analog	0 - 10V, R _i >100 kOhm	
Outputs (interface option)		
- Digital	potential-free relay contacts max. 70V, 500 mA, 10W	
- Analog	0 - 10V, max. 1 mA	
Dimensions (w x h x d)	241 x 88 x 264 mm (9.5" x 3.5" x 10.5") ½ of 19" rack insert, 2 height units	
Weight: without PFO / with PFO	2.6 kg (5.7 lbs) / 3.4 kg (7.5 lbs)	

Options

- Service box for PM-4: 600BS-29NN (picture 1)
- Connection of 2 sensors
- RS485 interface
- Master slave adapter for synchronizing 2 valves
- Customer specific software on request
- Blank panel for installation into 19" rack: 64263-R1 (picture 2)
- Installation kit for connecting 2 controllers in a 19" rack: 64263-R2

picture 1



picture 2

