





Model 614 RBL-G2

Tri Tool's Split-Frame "Clamshell" Lathes are the ultimate rotating platform for a wide range of applications from in-line pipe cutting, precision weld preparation, to specialized machining and milling operations.

Table of Contents

Overview	4
600 Series Features	5
14" to 60" RBL-G2 Clamshells	7
1" to 60" SB Clamshells	9
SB Thin-Wall Cutting	11
Clamshell Accessories	12
Special Engineering	13
Specifications	16
Clamshell On-Site Service	18
Clamshell Rental Options	18

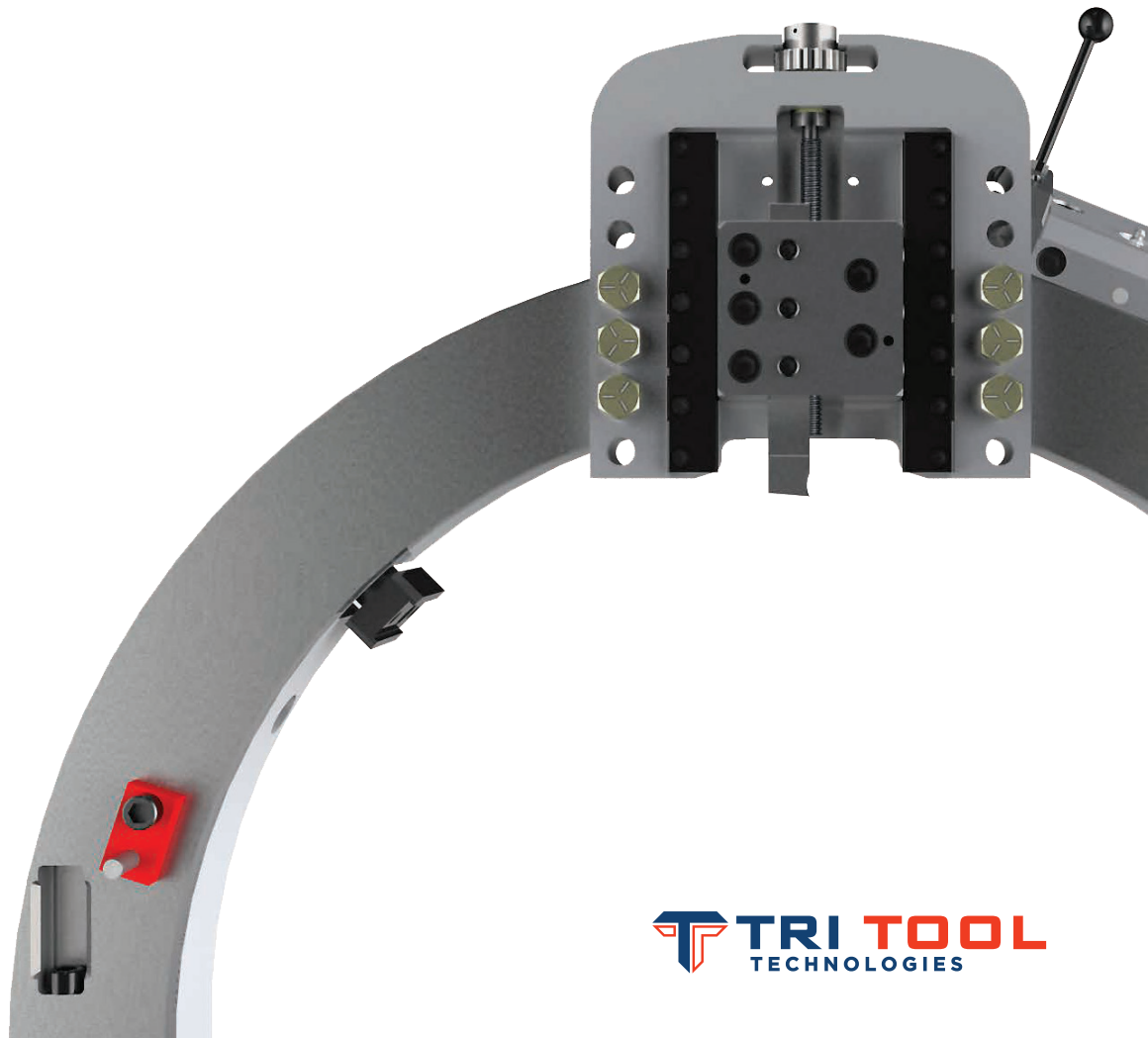

Overview

Tri Tool's reputation has been built on the precision, durability and overall quality of our equipment, so you can trust that you are using the best tool for your specific challenge. Our 600 Series Clamshells are engineered to handle any application; any pipe size or material and our machine tool experts are available to ensure you get the right equipment to fit your needs.

Features:

- Best-In-Class Precision
- Designed for Maximum Durability
- Both In-Line and End Prep Versatility
- Cold Cutting - No Heat Affected Zone
- Rapid, Dependable Performance
- A Comprehensive Range of Accessories

Tri Tool clamshell lathes produce superior results, being able to consistently deliver exacting diameter and surface tolerances within thousandths of an inch, making them ideal for use with advanced orbital welding systems.

Another advantage is that a clamshell can simplify cutting and rewelding of pipe by performing both precision pipe severing and weld end preparation simultaneously.

Easy to setup and operate, Tri Tool 600 Series Clamshells offer reduced labor and time requirements for pipe and component replacement, the perfect solution for plant maintenance where downtime is a critical economic issue.

Our unique bit designs for the clamshell lathes allow for optimal machining speed and feed rates. Their simple, reliable feed control provides the flexibility to perfectly match the cut depth for any material.

Designed specifically to operate in areas of tight clearances, these machines provide features that permit them to machine pipe in a wide range of situations where no other equipment can be used.

Clamshells are cold cutting and can be used in controlled environments where flame cutters are unacceptable.

They can be operated by remote control, making them perfectly suited for machining operations in nuclear, explosive, toxic, underwater and other hazardous workplace environments.

The machine's tool blocks are heat-treated for durability. Parts that could be damaged, such as gears, pins, and bearings, are protected to reduce the chance of accidental damage. Our clamshells do not have moving gears that protrude, providing increased operator safety.

When your work demands ultimate precision and durability in in-line/end-prep equipment, choose Tri Tool's 600 Series Split-Frame Lathes for guaranteed performance and reliability.

600 Series Features

Through field-proven design experience, our legendary SB, and second generation RBL-G2 lathes offer unique advantages.

Tri Tool 600 Series clamshell lathes are manufactured in two distinct types, the RBL-G2 type, and the SB. The different types offer distinct features, and cover the full range of standard pipe sizes and wall thicknesses. We provide optimal cutting configurations with benefits uniquely suited to your specific work requirements.

RBL-G2 Series

The second generation RBL-G2 clamshells' adjustable vee-track bearings are ideal when maximum portability is a prime consideration. The reduced-friction and drag of the roller bearings result in more power focused on the cut for faster operation. Requiring less input power, most roller bearing lathes can operate efficiently with a single drive motor. An optional second drive motor can be used to provide additional horsepower when required.

The lightweight design of the RBL-G2 allows for easier setup and handling. Long-travel, spur gear driven tool modules deliver smooth feed across the wide pipe size range. Mounting points for 2 tripper assemblies provide maximum allowable tool feed for different materials, reducing required cutting time. Optional tool modules and machining accessories are available for heavy-wall cutting.

SB Series

The venerable SB (Sliding Bearing) lathes feature adjustable full-contact bearings for maximum strength, providing the ultimate solution for simultaneous severing and beveling, deep counterbores, and close tolerance machining.

The signature sliding bronze bearings provide maximum stability for a smooth finish, precision machining, and long tool bit life, even on the most demanding materials. In harsh or contaminated environments such as offshore oil platforms or nuclear power plants, sliding bearings can be easily and economically cleaned and adjusted, maintaining consistent operating performance.



A 600 Series SB Clamshell performing a deep counterbore, critical to a pipe end-matching operation on an Oil and Gas Pipeline project.

Standard tool modules for the SB Series require minimal radial clearance, important when working where space is limited. A vast array of accessories are available for cutting extra heavy-wall pipe, as well as a wide range of specialized uses.

Special Applications

As a stable, precision rotating platform, the dependable split-frame clamshell lathe can be configured for countless in-place machining operations besides conventional severing and beveling. These operations include socket weld removal, counterboring, and single-point machining.

SB Clamshells represent the ideal solution to salvage expensive welded fittings and for performing seal weld cutting between pipes and bulkheads (in locations that provide sufficient mounting space to permit the radial clearance needed for machine rotation).

For socket weld removal, adjustable clamp pads center the clamshell with the tool bit positioned over the socket weld. An auto-feed tool module feeds the bit radially and machines the weld fillet back to the socket face.



The split-frame design of the Clamshell lathe allows the machine to separate and mount around the OD of in-line pipe or fittings for strong, stable clamping.

Pipe Size in Inches

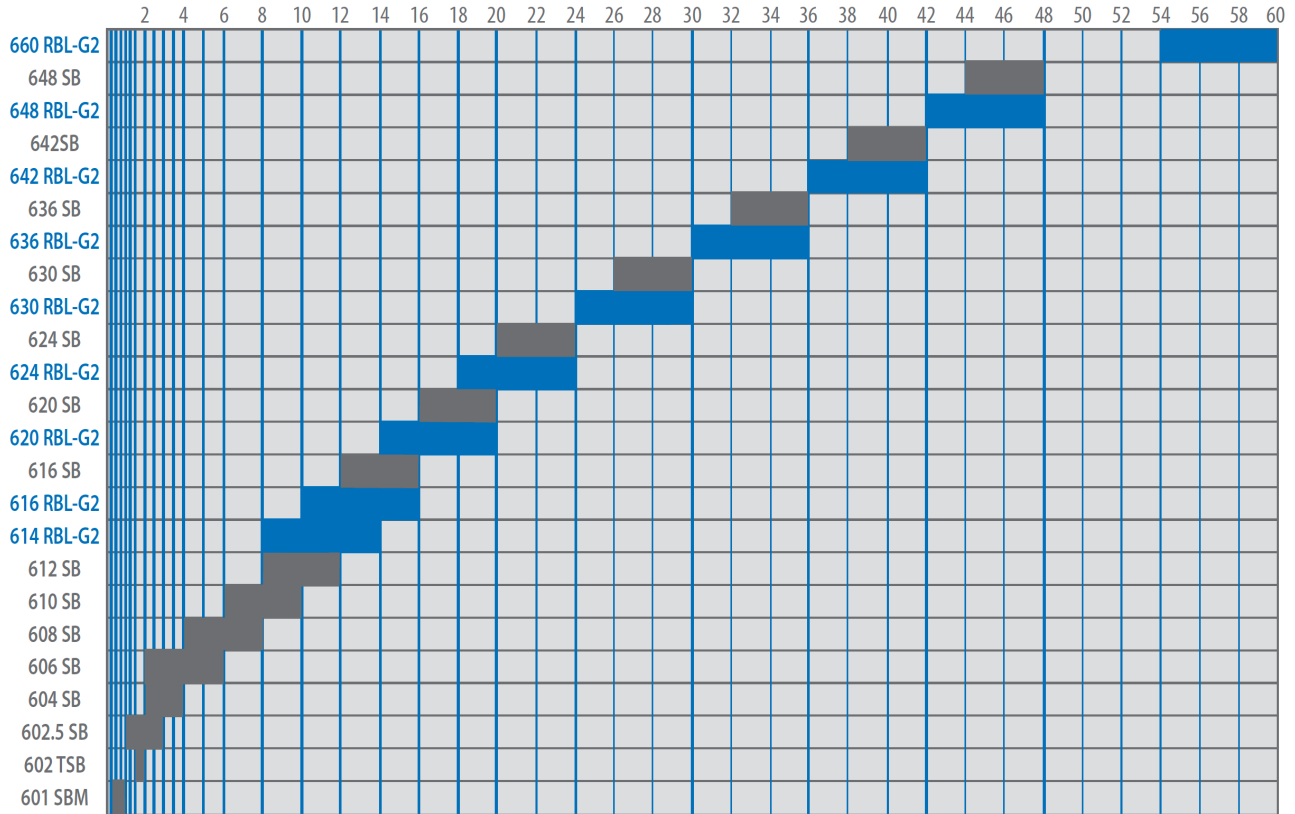

When using optional or custom accessories with 600 Series lathes, the actual cutting range may be extended wider, higher, or lower than those shown. Refer to the Specifications on Page 18 of this brochure, or contact your Tri Tool technical sales representative for more information.

Reliable, Precise Counterbores

Our Counterbore Modules (CBM) produce a precision counterbore on the inside wall of a pipe end immediately following a cut. Because they are mounted directly to the clamshell without repositioning, they consistently provide a uniform bore perpendicular to the cut face.

An additional feature of the CBM-3 counterbore module is a taper boring adjustment for 0° to 30° chamfers or lead-out angles.

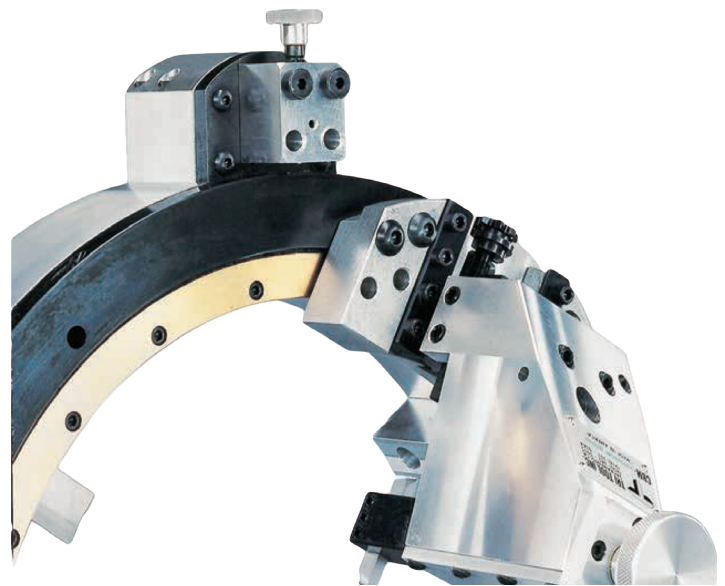

Model CBM-2 Counterbore Module

The Counterbore Module's capability for precision counterbores without changing machines (while the Clamshell is still in perfect alignment to the cut) is a significant advantage.

Model	RBL-G2 Clamshells	SB Clamshells
CBM-1	n/a	601 to 602.5
CBM-2	n/a	604 to 612
CBM-3	n/a	616 to 648
CBM-4	614 to 642	n/a

14" to 60" RBL-G2 Clamshells

The advanced 600 Series RBL-G2 represents the next generation in split-frame lathe design with safety as the top priority. Get Top performance with the durability you expect from Tri Tool.

In addition to addressing safety, Tri Tool examined every aspect of the clamshell lathe design and improved performance, speed and ease of use while maintaining the power and durability our customers have come to expect. The redesigned RBL-G2 will now sever and bevel up to three times faster with a high speed, in-line and right angle motor options in a single drive housing adding flexibility and reducing machining time without compromising power.



Model 624RBL-G2

Faster. Better. Safer

“We’ve also simplified the tool bit setup which should save the operator time and reduce the amount of training needed to operate the machine”

A. Ferozepurwalla

Custom Engineering Manager.

An economical high speed carbide sever kit allows for sequential sever and bevel operations with minimal setup and without having to reposition the clamshell lathe.

The RBL-G2 clamshells are designed to sever and bevel 7" through 60" in-line tube and pipe. They feature precise, lightweight vee-track roller bearings which feature low drag, with lower weight to maximize portability. As with our venerable SB series, set-up and operation of the RBL-G2 clamshell is simple and straightforward.

The RBL-G2 design provides adjustable bearings and tool slides to ensure long and dependable operation.

Our wide range of clamshell sizes and models permit excellent matching of equipment to the work. Simultaneous sever and bevel operations are possible for most wall thicknesses.

Safety is our first core value at Tri Tool and was the primary goal for our engineers when tackling this redesign effort.

Split-frame roller bearing lathes provide the highest degree of portability for applications where lighter weight and easier handling is an important advantage.

Our patented tool module along with the integration of a fixed-position tripper mechanism with the drive housing, and the tapered drive housing design minimizes pinch points for superior operator safety.

Features:

- Pinch points minimized for improved safety.
- The high-speed in-line motor option severs and bevels up to 3x faster for higher productivity.
- Patented tool module provides stability for smooth operation and superior surface finishes.
- A low-profile tripper increases operator safety.
- Corrosion-resistant coatings increase tool durability for long lasting protection in the roughest environments.
- Simplified tool bit setup saves time and minimizes training.
- Extended-reach tool modules for deep severs .
- Economical high speed carbide sever kit allows for sequential sever and bevel operations with minimal setup.
- Low friction, field adjustable, roller bearing system
- Requires low input horsepower.
- Lightweight, easy to setup.
- Tool modules with spur gear drive for finer feed increments.
- Cold cutting - means no heat affected zones.
- Modular design to enhance interchangeability of parts.

Low Profile RBL-G2 Tripper

“We wanted to eliminate as many pinch points on the RBL-G2 as possible. Our engineering team developed an innovative, patented tool block design that allows for the tripper mechanism to remain in a fixed and low-profile location adjacent to the tapered drive housings. The result is significantly fewer pinch points throughout the entire usable range of the machine”

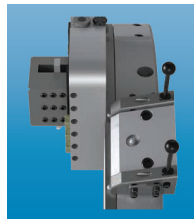

Justin Tripp

VP of Engineering



The high performance, second generation RBL-G2 brings improved speed and safety over the field proven RBL series of split frame lathes.

48" to 60" RBL-G2 Lathes

The versatile , field proven 648 - 660 RBL-G2 clamshell lathes utilize cutting modules and surface treatments that are different from those used with the 614-642 RBL-G2 clamshell lathes. Refer to the Specifications on Page 14 of this brochure, or contact your Tri Tool technical sales representative for more information.



For reliable pipe cutting in tight spaces, the slim design RBL-G2's are the perfect solution.

1" to 60" SB Clamshells

Portable Machine Shop Precision



Model 612SB

Model 606SB

Model 606SBM

The split-frame SB lathes offer the precision and power to sever and bevel a wide range of pipe sizes in the most demanding applications.

The Model SB Series lathes are designed for severing and beveling pipe from 1" through 60" and offers tool modules and accessories for a wide range of cutting operations from OD Tracking modules to complex, heavy-wall single-point machining. The large SB clamshells produce otherwise unattainable levels of accuracy and control, critical to pipe welding operations in heavy industry and power production. Because of the clamshell's power and superior stability, it is ideal for new construction, in-place maintenance, component replacement, decommissioning and production.

The 3 Position Tool Holder Increases Cut Range for 6 - 12" SB Clamshells

A tool holder for use with the Model 606 through 612 SB Clamshell permits cutting on pipe that is one size smaller than before. The 3 Position Tool Holder is standard with all 606SB through 612SB Clamshells, and is available as an optional accessory for customers with existing SB clamshells in that range.

Features:

- Guarded tripper mechanism for operator safety.
- Simultaneously sever and bevel on thin or heavy-wall pipe.
- Numerous drive options.
- Adjustable OD mounting system featuring locator pads & jackscrews for maximum stability.
- Excellent for working in tight spaces with little clearance.
- Extend capabilities with additional machining accessories.

SB Model	Previous Pipe Size Range	Range With Three Position Tool Module
606 SB	4" to 6"	2" to 6"
608 SB	6" to 8"	4" to 8"
612 SB	10" to 12"	8" to 12"



A piping system contractor performing outage maintenance on thin-wall stainless piping system uses an electrically powered SB clamshell fitted with full support pads. The piping system was part of an auxiliary high purity nitrogen supply line at a semiconductor manufacturing facility. A prefabricated pipe assembly was then orbitally welded in place without any additional end-prep being required.

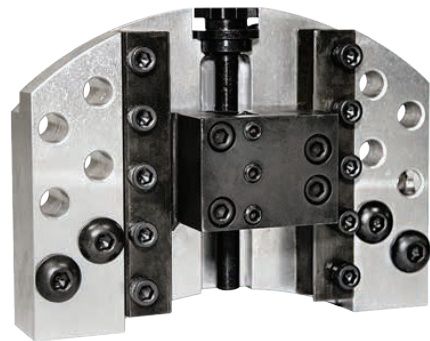

The 3 Position Tool Holder mounting bolts (shown) can be mounted in one of the three positions to shift the module in or out to accommodate different pipe sizes.

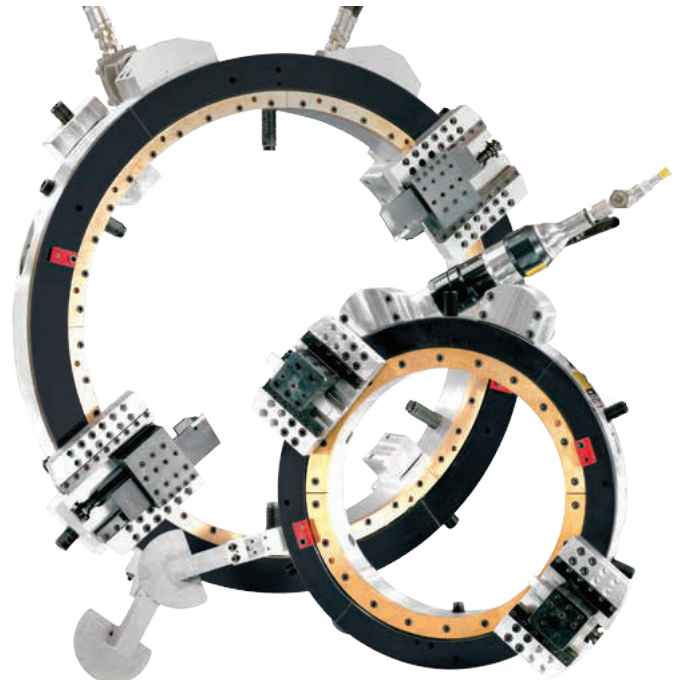

Model 630SB

Model 616SB

SB Thin-Wall Cutting

The versatility of our 600 Series SB Clamshells is demonstrated by the precision severing that can be achieved for exacting thin-wall applications.

The smooth, precision cutting characteristics of the SB Clamshell are ideal for severing and beveling of thinner wall Schedule 5 to 10 pipe and tube, making them perfect for use in the semiconductor, pharmaceutical, chemical, and food processing industries.

Proper cutting of a typical .062" to .250" wall requires some specialized accessories to prevent deformation created by clamping forces of mounting pads. Other considerations are tracking the OD and rounding methods, all designed to produce a consistent land thickness and profile.

Mounting pads are size specific for the pipe or tube being worked on and pad sets are typically aluminum but can be made from different materials (such as stainless steel or plastic) depending on requirements.

Full Support Pads

Clamshells use full support pad sets for severing and beveling thin-wall pipe and tube. Full Support Pads provide excellent distribution of clamping forces.

Full support pads can be utilized for pipe sizes up to 1" less than a Clamshell model's maximum mounting specification. Full support pads spread the mounting forces equally over a much larger area, protecting thin-wall pipe from warping or distortion, providing a secure grip, and helping to reshape out-of-round conditions.

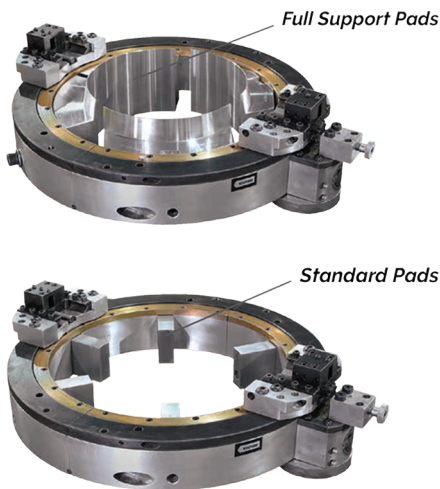

In the 612SB Clamshell shown above, the increased surface area of Full Support Pads is clearly seen. While conventional Clamshell mounting pads provide secure grip on regular to heavy wall pipe, they can focus strong clamping forces that could distort and deform thinner wall thicknesses.

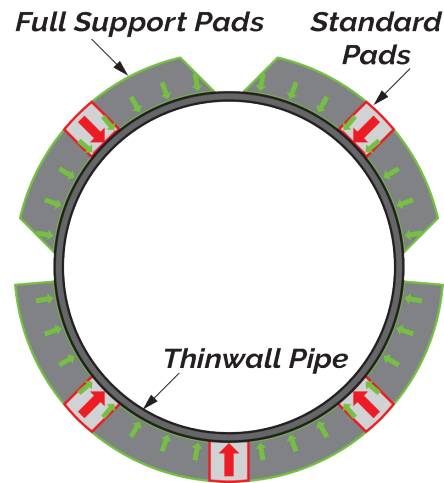

An illustration showing distribution of clamping force, a comparison is easy to make between the standard (Red) and Full Support Pads (Green).

Clamshell Accessories

Reversed Drive Housing

Designed specifically for use in tight clearance situations, the reversed drive housing optionally positions the drive motor on the front side of the lathe.

Back Mounted Support Rings

For special situations requiring additional rigidity or mounting flexibility, back support rings can be added. The back support rings provide a second row of offset jackscrews for improved mounting force distribution and positioning control.

Roller Cutters

Also known as "chippless" cutters, roller cutters use sharp-edged wheels to sever thin wall tube or pipe. The cutting wheel is progressively fed into the pipe, displacing metal as it rolls, producing a cut without chips. This is valuable when chip contamination is a concern.

Template Tracer Modules

This module is used to produce complex bevels on open-ended pipe. The template tracer follows a fixed profile template in order to transfer the desired bevel configuration to the pipe end when using single-point machining techniques.

OD Tracking Modules

When working with "out-of-round" pipe, the OD tracking module uses a wheel which follows the pipe's outside diameter, constantly adjusting the tool bit position to provide the most consistent land thickness and bevel possible.

Automatic Tripper Disengage

The automatic tripper assembly features a spring-loaded pin that stops the tool bit feed at a preset travel point to control the depth of cut.

Most of our Clamshell lathes can be powered by air, hydraulic, or electric motors configured to match the input power requirements of the work being done.

Note that an "Air Caddy" (In-line air filter/lubricator) is required for all Tri Tool equipment that uses pneumatic drive motors.

Choose the Power Source you need.

12

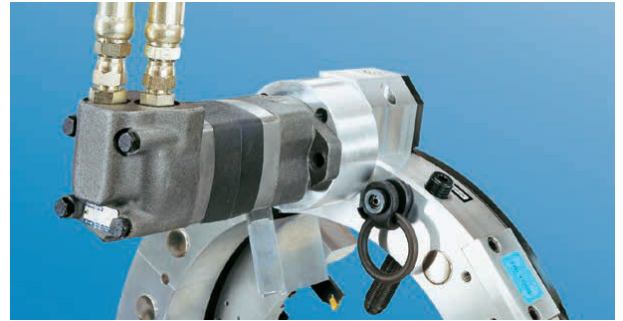

Single Hydraulic Motor.



Single or Dual Pneumatic Motors used in tandem (shown).

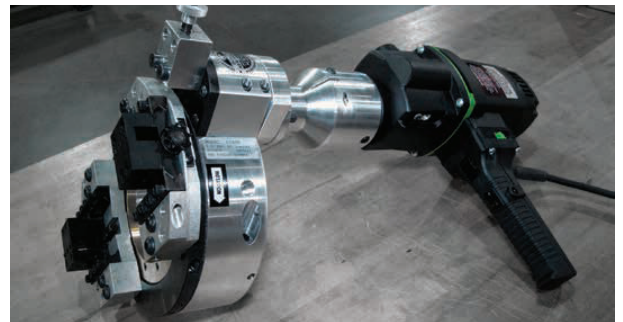

An Electric Motor is an option for quiet dependable power.

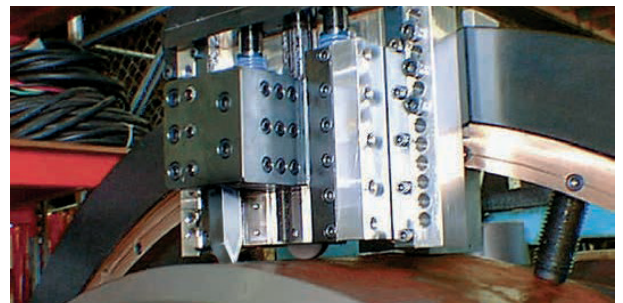

An OD Tracking Module accessory being utilized on a large SB clamshell. The Tracking Module compensates for out-of-round conditions by "reading" the pipe shape with a wheel, automatically adjusting cut depth.

Special Engineering

Even with an extensive standard product line, some applications still require special engineering support.

With extensive OEM manufacturing experience and unique special engineering capabilities we can help with all your special needs. Cutting capabilities can be expanded by modifying standard equipment or with custom accessories.

Our engineering department has experience in providing machine tool solutions to satisfy the most rigorous and demanding specifications for a wide range of industries.

Typical special engineering applications fall into several main categories which address specific elements of the machining process.

Clamping

Special accessories can be designed to clamp unique shapes or sensitive materials, difficult or automated cutting procedures to be performed or to provide extreme accuracy.

Automatic Bit Feed and Shut-Off

Standard manual tripper control pin mechanisms are not suitable for some remote operations or some specific cutting procedures. In those instances, special accessories have been developed to provide remote control over tool bit feed rate, machining speed, and depth of cut shut-off.

Special Tool Bits and Tool Bit Holders

Some situations or materials require the development of custom tooling to generate specific machining results. Special bit holders can be produced to replace the standard tool holders.

Remote Operation

An ongoing requirement of special engineering is for remote control when the clamshell is employed in hazardous environments.

Construction and maintenance projects being performed underwater require that the equipment be set-up by divers, a situation in which the clamshell's easy set-up is a clear advantage. While it is possible for a diver to operate the machine, the equipment can be powered, controlled and monitored from above.

Another need for remote operation arises in the nuclear power industry. Many of the critical maintenance operations are performed in high radiation areas where equipment characteristics such as reliability, precision and ease-of-use are not merely advantageous - they're mandatory.



Clamshell mounted saw with video camera, designed for remote seal repair in a nuclear power plant.

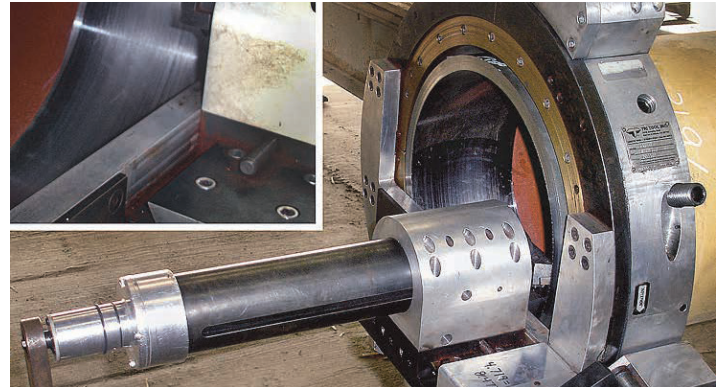

Clamshell configured to perform extremely accurate deep counterboring.

Complete remote control stations can be developed to control maintenance projects involving the use of clamshells to limit the exposure of personnel to radiation during operation.

As a stable rotating platform, the clamshell lathe can accept numerous accessories such as video cameras to monitor the work being done. Many maintenance operations in nuclear plants involve replacement of critical piping systems, fittings, and components.

The ability to cut with extreme accuracy without generating contaminated fumes or grinding debris makes the safety and control of the cold cutting operation superior to any other method. The clamshell, when combined with Tri Tool custom equipment manufacturing, has proven uniquely able to solve numerous problems for the nuclear industry in construction, maintenance, storage, decommissioning, and clean-up operations.

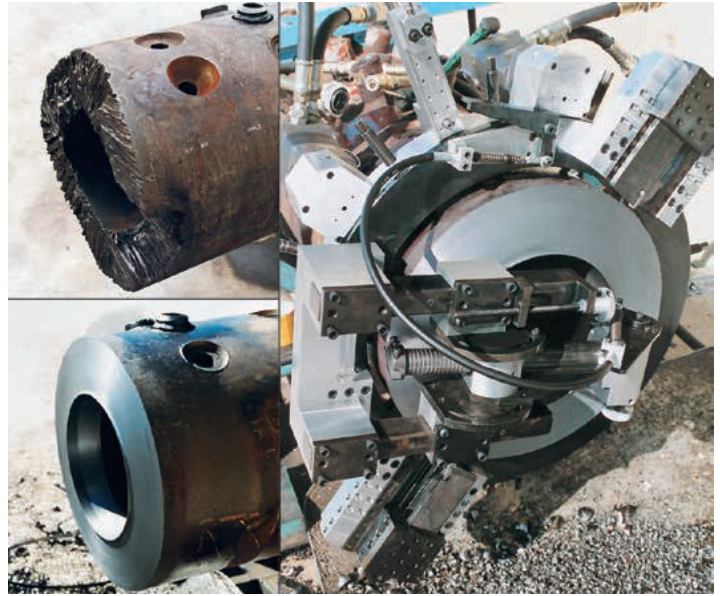

A custom configured 600 RBL series split frame lathe configured with a single point machining module generating a precision heavy wall "J Prep" weld profile and counterbore on a flame-cut pipe end.

Special Operations

Accessories have been developed to perform many different operations such as to allow the OD mounted SB clamshell to be ID mounted for inside-out cutting.

Other examples include chipless roller wheel cutting with milling tools, automatic welding, grooving and other types of end finishing.

While the need for a completely custom clamshell is usually not required, the importance of a critical or repetitive task can justify the need for custom machinery.

Tri Tool's special engineering team can develop and manufacture custom equipment based on proven designs, to meet virtually any project requirement or specific work situation. The clamshell lathe is an excellent choice for special OD mounted pipe machining applications.

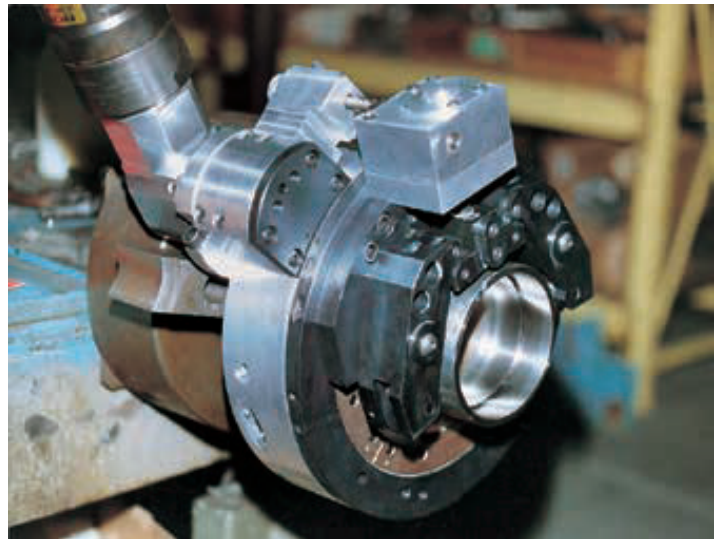

A small SB lathe fitted with a cut-off wheel module performs "chipless" cutting of thin-wall tubing.

You can depend on Tri Tool special engineering for thorough and experienced technical design and custom manufacturing assistance for any cutting or welding requirements you may have.

Clamshell/AdaptARC® Welding Solution for Power Plant Shaft Repair

Tri Tool special engineering provided custom design and manufacturing for a comprehensive repair system that was successfully used to repair a power plant shaft. The damaged shaft surface was first milled away, re-welded with an AdaptARC® system, then precision machined to restore the final critical dimensions. All machining and welding operations were performed while mounted on a custom SB Clamshell.



A Tri Tool DualARC® Weld Head is shown mounted to a custom SB Clamshell lathe performing a fill-in weld on a shaft the SB has previously machined.

600 Series Clamshells are the Ideal Platform for Specialty In-Line Applications.

As a precision bearing lathe that can be split into two or more sections, the RBL-G2 and SB Clamshells have proven themselves time and time again as the ideal platform that can be configured for virtually any in-line machining procedure including milling, grooving, weld profiling, coating removal.

With the winning combination of a secure mounting system, and rigid frames, our 600 Series machines produce excellent finishes and rapid results for countless projects in numerous industries.



This Clamshell lathe has been configured to perform precision, in-line weld-profiling to strengthen weld joints for offshore platform tendon legs.

Specifications

(RBL-G2 Type Lathe Shown)

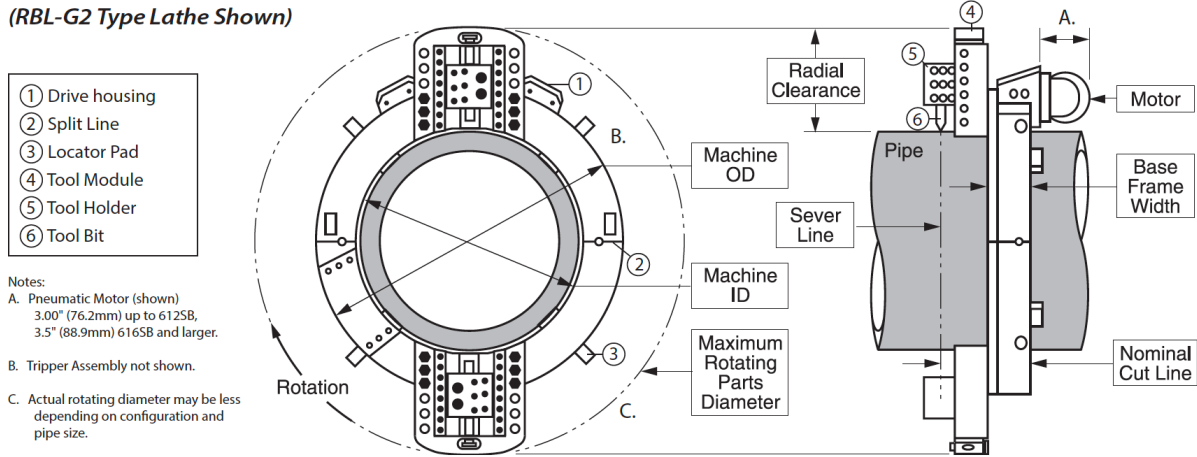

Model	Pipe Size Range Inch (mm)	Radial Clearance Inch (mm)	Machine Weight lbs. (kg)	Rotating Parts Diameter Inch (mm)	Machine OD Inch (mm)	Machine ID Inch (mm)	Base Frame Width Inch (mm)	Nominal Cut Line Inch (mm)
601 SBM	1/4 (13.7) - 1 (33.4)	2.00 (50.8)	11.5 (5.2)	5.31 (134.9)	5.31 (134.9)	1.44 (36.6)	2.00 (50.8)	3.50 (88.9)
602 TSB	*1 1/2 (38.1) - *2 (50.8)	1.49 (37.8)	12.0 (5.4)	4.98 (126.5)	4.98 (126.5)	2.10 (53.3)	2.50 (63.5)	4.00 (101.6)
602.5 SBM	1 (33.4) - *3 (76.2)	1.94 (49.3)	14.5 (6.6)	6.87 (174.5)	6.87 (174.5)	3.13 (79.5)	2.00 (50.8)	3.50 (88.9)
604 SB	2 (60.3) - 4 (114.3)	2.25 (57.2)	29 (13.1)	9.00 (228.6)	9.00 (228.6)	4.75 (120.7)	3.00 (76.2)	4.50 (114.3)
606SB	3 (88.9) - 6 (168.3)	4.29 (109.0)	37 (16.8)	15.12 (384.0)	11.12 (282.4)	6.87 (174.5)	3.00 (76.2)	4.50 (114.3)
608 SB	4 (114.3) - 8 (219.1)	4.29 (109.0)	43 (19.5)	17.12 (434.8)	13.12 (333.2)	8.95 (227.3)	3.00 (76.2)	4.50 (114.3)
610 SB	6 (168.3) - 10 (273.1)	4.56 (115.8)	55 (25.0)	19.78 (502.4)	15.75 (400.1)	11.20 (284.5)	3.00 (76.2)	4.50 (114.3)
612 SB	8 (219.1) - 12 (323.9)	4.56 (115.8)	62 (28.1)	21.78 (553.2)	17.75 (450.9)	13.20 (335.3)	3.00 (76.2)	4.50 (114.3)
616 SB	12 (323.9) - 16 (406.4)	6.55 (166.4)	200 (91)	29.10 (739.1)	24.00 (609.6)	17.00 (431.8)	4.25 (108.0)	6.93 (176.0)
620 SB	16 (406.4) - 20 (508.0)	6.63 (168.4)	320 (145)	33.25 (844.6)	29.20 (741.7)	21.20 (538.5)	4.90 (124.5)	7.58 (192.5)
624 SB	20 (508.0) - 24 (609.6)	6.70 (170.2)	350 (159)	37.40 (950.0)	33.40 (848.4)	25.40 (645.2)	4.90 (124.5)	7.58 (192.5)
630 SB	26 (660.4) - 30 (762.0)	6.75 (171.5)	420 (191)	43.50 (1104.9)	39.50 (1003.3)	31.50 (800.1)	4.90 (124.5)	7.58 (192.5)
636 SB	32 (812.8) - 36 (914.4)	7.05 (179.1)	490 (223)	50.10 (1272.5)	46.00 (1168.4)	38.00 (965.2)	4.90 (124.5)	7.58 (192.5)
642 SB	38 (965.2) - 42 (1066.8)	7.10 (180.3)	570 (259)	56.20 (1427.5)	52.00 (1320.8)	44.00 (1117.6)	4.90 (124.5)	7.58 (192.5)
648 SB	44 (1117.6) - 48 (1219.2)	7.15 (181.6)	820 (372)	62.30 (1582.4)	58.00 (1473.2)	50.00 (1270.0)	5.75 (146.1)	8.43 (214.1)
614 RBL-G2	*7 (177.8) - 14 (355.6)	8.24 (209.3)	146 (66)	30.24 (768.1)	21.10 (535.9)	15.00 (381.0)	3.31 (84.1)	6.25 (158.8)
616 RBL-G2	10 (273.1) - 16 (406.4)	8.28 (210.3)	159 (72)	32.34 (821.4)	23.10 (586.7)	17.00 (431.8)	3.31 (84.1)	6.25 (158.8)
620 RBL-G2	14 (355.6) - 20 (508.0)	8.30 (210.8)	184 (83)	36.44 (925.6)	27.10 (688.3)	21.00 (533.4)	3.31 (84.1)	6.25 (158.8)
624 RBL-G2	18 (457.2) - 24 (609.6)	8.46 (214.9)	207 (94)	40.79 (1036.1)	31.10 (789.9)	25.00 (635.0)	3.31 (84.1)	6.25 (158.8)
630 RBL-G2	24 (609.6) - 30 (762.0)	8.49 (215.6)	239 (108)	46.89 (1191.0)	37.10 (942.3)	31.00 (787.4)	3.31 (84.1)	6.25 (158.8)
636 RBL-G2	30 (762.0) - 36 (914.4)	8.53 (216.7)	264 (120)	52.99 (1345.9)	43.10 (1094.7)	37.00 (939.8)	3.31 (84.1)	6.25 (158.8)
642 RBL-G2	36 (914.4) - 42 (1066.8)	8.53 (216.7)	305 (138)	58.86 (1495.0)	49.10 (1247.1)	43.00 (1092.2)	3.31 (84.1)	6.25 (158.8)
648 RBL-G2	42 (1066.8) - 48 (1219.2)	9.00 (228.6)	940 (427)	67.50 (1714.5)	60.00 (1524.0)	50.00 (1270.0)	5.13 (130.3)	7.97 (202.4)
660 RBL-G2	54 (1371.6) - 60 (1524.0)	9.00 (228.6)	1120 (508)	79.50 (2019.3)	72.00 (1828.8)	62.00 (1574.8)	5.13 (130.3)	7.97 (202.4)

The specifications listed above are presented to illustrate the wide range of configurations possible. Custom configurations are available.

Call your Tri Tool sales representative for assistance in determining which equipment and accessories are right for your requirements.

Measurements are for the basic machine fitted with standard tool modules. Optional low axial dimension tool modules are available for the 601SBM and 602.5SBM, and 606SB through 612SB. Radial Clearance and Max Rot. Dia. for 606SB to 612SB is shown for the standard 3 Position Tool Module. Note: Measurements will vary from those indicated when machinery is configured for different pipe sizes and with different height tool modules. **Pipe size range** is based on ANSI pipe dimensions. Pipe sizes indicated with (*) indicate tube sizes, not pipe sizes. **Machine weight** is the lifting weight of the machine which includes the basic machine with standard tool modules. **Rotating parts diameter** is the dimension across the face of the machine, including its moving parts (inner ring and standard tool modules) when the machine is set-up for the maximum pipe size for the specific model. The rotating parts diameter becomes less when tool modules are positioned inward to reach smaller pipes or when using special, low profile, or multiple position tool modules. **Nominal cut line** is the dimension from the back of the machine to the center line of the tool bit slot.

This information is provided as a guideline only to assist with the selection of equipment and accessories. This information is subject to change without notice. Contact your sales representative for specific details or technical specifications.

● Standard
○ Special

Model	Tool Modules						Tool Holders and Machining Accessories						Drive Options					
	Standard Modules (Low Profile)	Extended Modules	3 Position Modules	Heavy-Duty Modules	Heavy-Duty Sever Modules	OD Tracking Modules	Socket Weld Removal Kit	Heavy-Duty Sever Tool Holders	Carbide Sever Tool Holders	Low Axial Clearance Tool Holders	Counterbore Module	Single-Point Module	Reversed Drive Housing Kit	Pneumatic (Single)	Pneumatic (Dual)	Electric (Single)	Hydraulic (Single)	Hydraulic (Dual)
601 SBM	● ¹						●				●		●					
602 TSB	●										●		●					
602.5 SBM	● ¹						●				●		●			●	○	
604 SB	● ²	●		○		○	●	○			●		●		●	○		
606SB	● ²	●	●	○		○	●	○			●		●		●	○		
608 SB	● ²	●	●	○		○	●	○			●		●		●	○		
610 SB	● ²	●	●	○		○	●	○			●		●		●	○		
612 SB	● ²	●	●	○		○	●	○			●		●		●	○		
616 SB	○	●		●	●	●		○	○	●	●	○		●				●
620 SB	○	●		●	●	●		○	○	●	●	○		●				●
624 SB	○	●		●	●	●		○	○	●	●	○		●				●
630 SB	○	●		●	●	●		○	○	●	●	○		●				●
636 SB	○	●		●	●	●		○	○	●	●	○		●				●
642 SB	○	●		●	●	●		○	○	●	●	○		●				●
648 SB	○	●		●	●	●		○	○	●	●	○		●				●
614 RBL-G2		●				●		●	●	●	●	○	●	●	●	●	●	●
616 RBL-G2		●				●		●	●	●	●	○	●	●	●	●	●	●
620 RBL-G2		●				●		●	●	●	●	○	●	●	●	●	●	●
624 RBL-G2		●				●		●	●	●	●	○	●	●	●	●	●	●
630 RBL-G2		●				●		●	●	●	●	○	●	●	●	●	●	●
636 RBL-G2		●				●		●	●	●	●	○	●	●	●	●	●	●
642 RBL-G2		●				●		●	●	●	●	○	●	●	●	●	●	●
648 RBL-G2		●				●		●	●	●	●	○	●	●	●	○	●	●
660 RBL-G2		●				●		●	●	●	●	○	●	●	●	○	●	●

Tool Modules (function)- Tool modules mount on the rotating face of the clamshell and carry the tool bits within the tool holder section. The tool bit is fed into (towards) the pipe a fixed increment for each revolution of the head stock with one tripper pin assembly engaged. Multiple trippers increase the total feed of the tool bit per revolution.

Standard (Low Profile) Tool Modules- Standard or Low Profile modules fit within the OD of the clamshell to minimize the radial clearance required. Normally they only function on the largest pipe size that fits within the Clamshell.

Extended Tool Modules- Extended tool modules provide longer tool bit feed travel and a greater pipe size range. When mounted for the largest pipe size that fits the clamshell the modules extend outside the OD of the clamshell, requiring more radial clearance, but also allow mounting inboard to reach smaller pipe sizes.

3 Position Tool Modules- Permit cutting on one size smaller pipe (compared to Extended Modules) when using a 606SB through 612SB Clamshell. **Heavy Duty Tool Modules-** Heavy Duty Tool Modules allow use of heavier tool bits for extremely heavy cutting operations.

Heavy Duty Sever Modules- Heavy Duty Sever Modules use part-off blades to extend the reach of the cutting tool for deep sever operations.

Tool Holders - Tool Holders install into the Tool Modules to allow the Module to perform different functions, fit limited space or use alternate tooling. **Machining Accessories**

- Socket weld removal kits contain the special tool holders and parts to equip the clamshell for machining the fillet welds off of a socket weld joint.
- Counterbore kits mount to the tool modules to allow the machining of a counterbore (on open ended pipe).
- Singlepoint modules provide full lathe type machining operations on open ended pipe.

Drive Motors- Clamshells can be driven with pneumatic motors which provide the maximum power per unit weight, electric motors for light duty machining (HP per unit volume restricts the maximum HP motors that can be fitted) and hydraulic motors which provide the maximum power and speed range capabilities at the machine (a separated power supply is required). Dual drives can be fitted for additional power and machining capabilities as required.

Special Options- Special options not shown include: full support pads for thin wall pipe or tube (some pipe size restrictions apply due to space requirements to incorporate the pads), out-of-round tracking modules to machine the prep concentric to the OD without rounding the pipe, custom tool bit configurations, back-support rings for added mounting rigidity, etc.

This information is provided as a guideline only to assist with the selection of equipment and accessories. This information is subject to change without notice. Contact your sales representative for specific details or technical specifications.

Clamshell On-Site Service

Get 600 Series versatility, along with experienced, reliable operation.

When you are challenged with an in-line machining requirement that you absolutely need to get done right the first time, call Tri Tool Services.

Their expert staff of experienced field machining and code welding technicians are backed with state-of-the-art equipment and OEM support. This guarantees that you get the experience and project-optimal equipment that your most important work requires.

Tri Tool Service technicians can perform a comprehensive range of machining and welding operations, and can assist you with new Clamshell purchases through on-location operation training, for your machining personnel or for your safety program.



This 600 Series Clamshell is being used with the mounting screws and tool modules turned to cut from the inside out. Tri Tool's Services can assist you with custom and innovative equipment solutions for all your special machining and code welding requirements.

Clamshell Rental Options

Tri Tool Clamshells can be rented, providing a cost-effective alternative for projects or unplanned outages.

Tri Tool maintains a nationwide network of stocked rental facilities to ensure that you get the equipment at competitive rates, when and where you need it. Offices in Rancho Cordova CA, Chattanooga TN, and Houston TX provide localized technicians and parts inventories, and you can return equipment to your nearest facility, saving you money.



Each returning Clamshell is thoroughly inspected and adjusted by expert technicians, ensuring "like new" operation and ready-to-rent status.

With our flexible rental program you can try out our equipment before you buy!

Should you decide that you want to buy the rented equipment within the first 30 days of rental, Tri Tool offers a pro-rated schedule that applies rental costs to a purchase price. You get up to a month's rental free!

Renting equipment with the option to buy is a popular and affordable way to experience first-hand, how a Clamshell lathe can be an important, versatile, high performance addition to your in-place machining equipment.

Call today for more information.

- Portable Precision Machine Tools
- MissionBuilt Custom Engineered Solutions

- On-site Field Services
- Equipment Rentals