

MAXIM 50

Dependable, Custom Performance

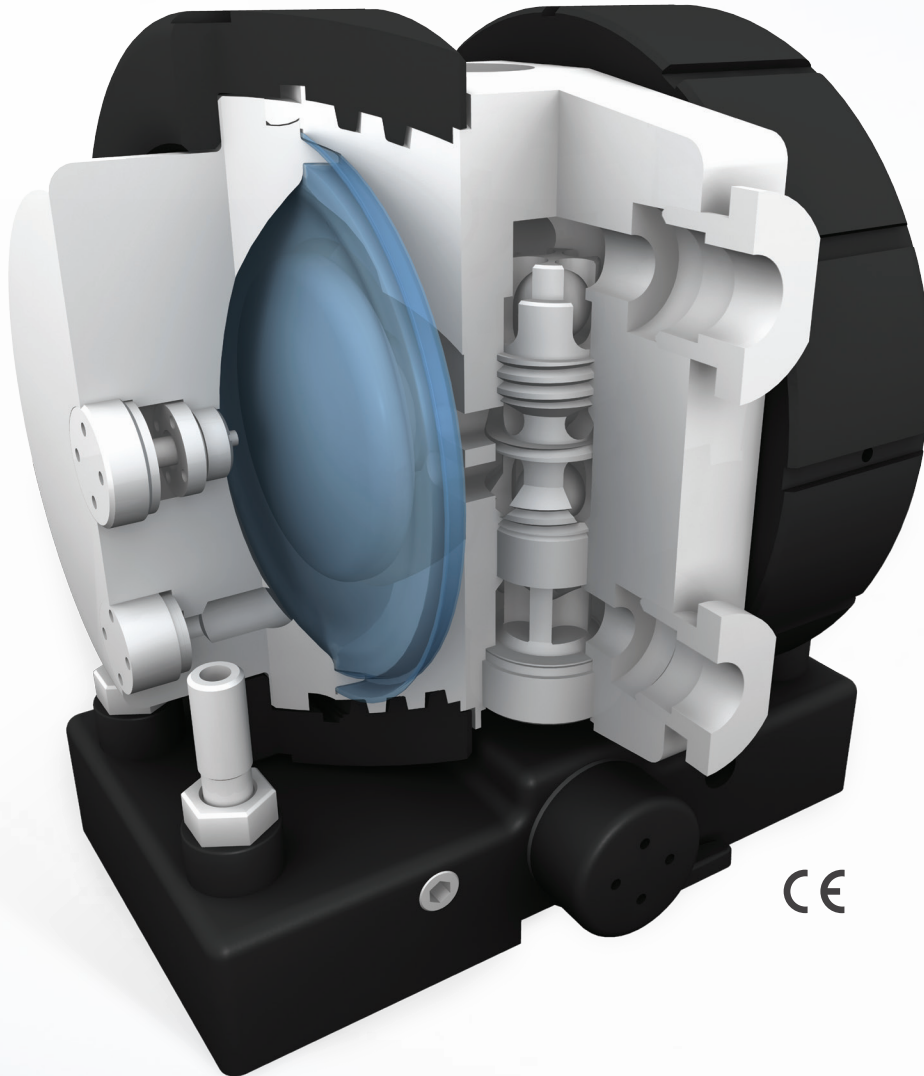

DIFFUSER HEAD
TECHNOLOGY

NON-PENETRATED,
DOUBLE LAYER
PTFE DIAPHRAGM

PTFE/PFA
FLUID PATH

SMART PILOT
TECHNOLOGY

QUICK RELEASE
BASE

The Maxim 50 is still one of our most popular pumps because of its reliability and control features. The pump was designed to withstand highly aggressive chemical applications and has been proven to withstand wear and chemical attack in chemical solutions that typically form crystals or suspend solids, which shorten the life of most pumps. In addition, the unique construction eliminates the need for O-ring seals.

This is PURE INNOVATION.



MAX FLOW
50 LPM / 13.2 GPM



MAX TEMPERATURE
180 °C / 356 °F M50R/E/U
100 °C / 212 °F M50D



MAX PRESSURE
80 PSI / .55 MPa M50D/E/U
60 PSI / .41 MPa M50R



DRY SUCTION LIFT
13' / 4m

TREBOR

treborintl.com

Trebor International | North/South America +1 800 669 1303 | Europe +49 9120 1804-65 | Asia +65 6684 7319

A Unit of IDEX Corporation

FLOW PERFORMANCE

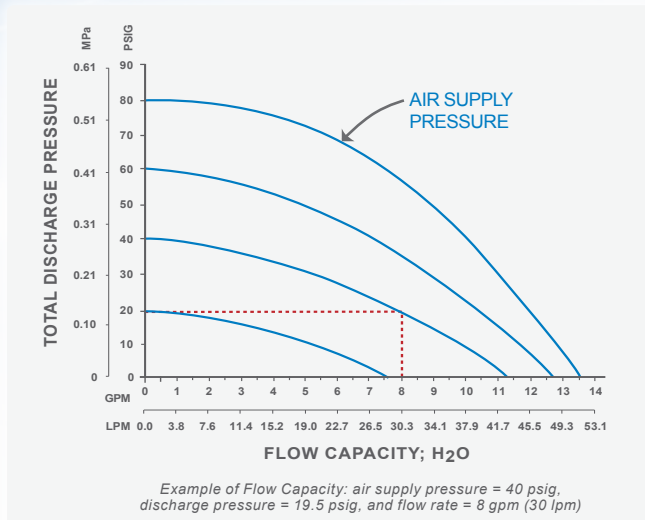

AIR CONSUMPTION

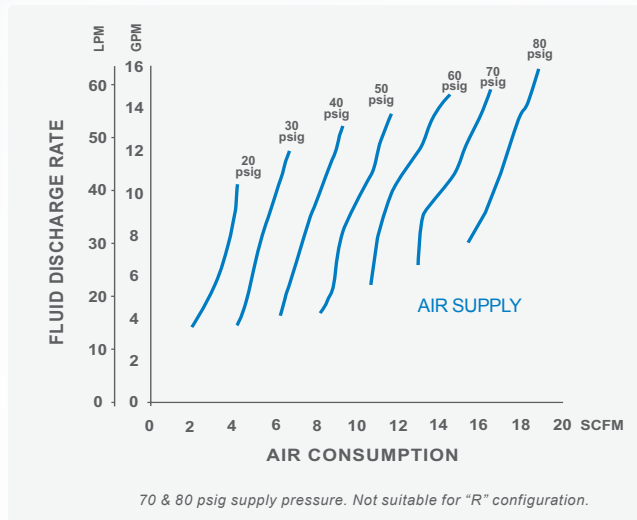

PUMP OPTIONS (LIMITED LIST SHOWN)

PUMP	M50R	Maxim 50 Recirculation Pump
	M50D	Maxim 50 Chemical Delivery Pump
	M50E	Maxim 50 External Control Pump with End-of-Stroke Probes (2 ea)
	M50U	Maxim 50 External Control without End-of-Stroke Probes
FLUID CONNECTION	00000	No Adapter Fitting
	B0800	1/2" Weldable PFA Pipe
	F0800	1/2" Flare Tube Adapter
	F1200	3/4" Flare Tube Adapter
	F1600	1" Flare Tube Adapter
	P1200	3/4" NPT Adapter Nuts
	T1200	3/4" PFA Tube Stubout
<i>More Options Available, Contact Trebor for Information</i>		
LEAK DETECTION	0	No Probe
	1	Leak Probes
OPTIONS	A0	No Option
	A2	Cycle Probe
	A4	Check Muffler
	A6	Polypropylene or PVDF Union Nuts
	B2	Remote Exhaust (M50R & M50D only)
	B3	Diffuser Head
<i>More Options Available, Contact Trebor for Information</i>		

DIMENSIONS IN MILLIMETERS (IN.)

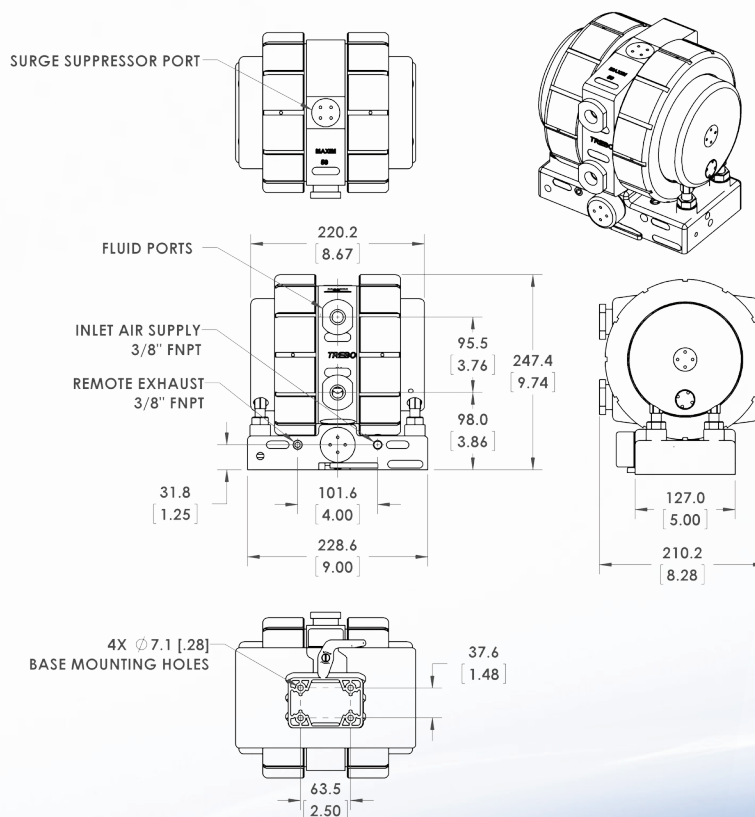

Example of an order number based on configuration options:

M50D F1600 1 A0
Compatible with our SS85 and SS95 Surge Suppressor

Trebor uses virgin PTFE and PFA in all products...no re-processed material is allowed.

Trebor International | North/South America +1 800 669 1303 | Europe +49 9120 1804-65 | Asia +65 6684 7319

treborintl.com

A Unit of IDEX Corporation

© Copyright 2016 Trebor, Inc. All rights reserved. MAXIM50_DS_REV0116

TREBOR®