

### Construction

The **CleanStar®** C60 / C67 HPS pneumatically or manually operated 2/2-way diaphragm valves have a complete PP body. All medium wetted parts are made of PP or PTFE (diaphragm). The external actuator parts are made of PVDF.

A stroke limiter and an optical position indicator are standard for C67 HPS. Both valves have integral solid mounting lugs and a leakage sensor connection.

### Features

- Metal-free (for C67 or C60 with control function 3)
- Low cost valve with PP body
- Improved flow capability
- Union nuts / flare connections compatible with all current designs
- Manufactured in a controlled environment

### Advantages

- Minimal contamination
- High Kv/Cv value
- Minimal deadleg
- Improved mounting system
- Optional flow direction

Thus you achieve:

- Reduced equipment flush times
- High reliability (MTBF)
- Reduced costs



C60 HPS

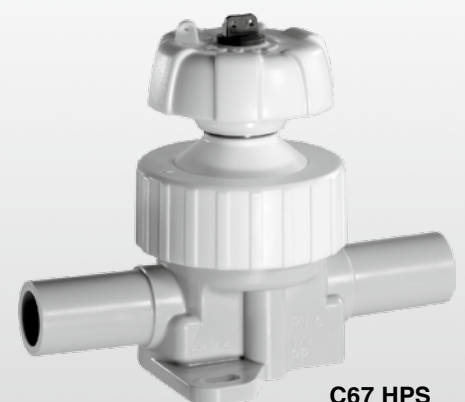

C67 HPS

### Actuator dimensions GEMÜ C60 HPS [mm/inch]

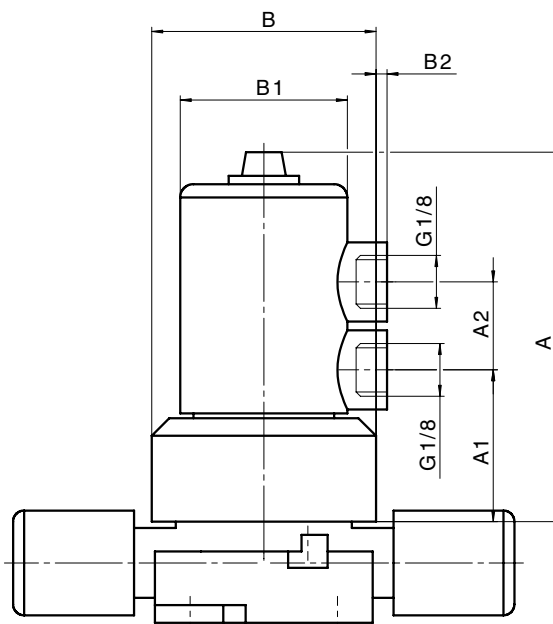

Actuator size	A	A1	A2	B	B1	B2
2	93/3.66"	35.4/1.39"	24.1/0.94"	63.0/2.48"	64.7/2.54"	9.5/0.37"
3	122.5/4.82"	35.0/1.37"	39.0/1.53"	79.0/3.11"	86.0/3.38"	12.5/0.49"

For connection dimensions see pages 5 and 6

## Technical data

### Operating medium

Corrosive, inert, gaseous and liquid media which have no negative impact on the physical and chemical properties of the body and diaphragm material.

### Operating pressure

Max. 6 bar when applied upstream only

Vacuum 400 mbar/abs\*

\* The life expectancy of the valve may be affected if exposed to a greater vacuum.

### Flow direction

Optional

### Operating temperature

See temperature/pressure diagram

### Ambient temperature

Max. 60 °C (130 °F)

### Materials

Media wetted parts (body)	PP
Diaphragm	PTFE
External actuator parts	PVDF

### Control pressure (only C60 HPS)

"Normally closed" 4 - 7 bar

"Normally open" and „Double acting“ max. 4 bar

For coordination connection size/actuator size see table page 3

### Control air connection (only C60 HPS)

Size G 1/8

### Pressure / temperature diagram

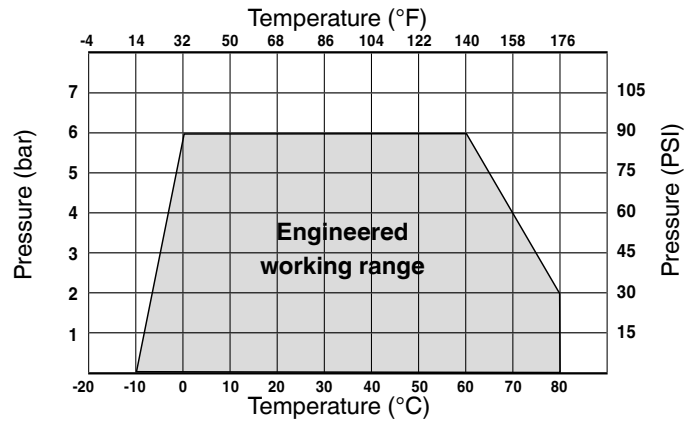

### Information on the use of the diagram

The temperature / pressure diagram is only an orientation aid. The data refer to water as a working medium. A change of operating conditions or other media may result in deviations. In case of doubt it is advisable to test the behavior of the material under the definitive operating conditions by means of a test installation.

Temperatures under 0°C can affect the operating speed negatively.

### Actuator volume C60 HPS



Actuator size	Control function	Code	Actuator volume [cm <sup>3</sup> ]
2	Normally closed	1	24.0
	Normally open	2	39.0
	Double acting (closed)	3	39.0
	Double acting (open)	3	24.0
3	Normally closed	1	56.0
	Normally open	2	88.0
	Double acting (closed)	3	88.0
	Double acting (open)	3	56.0

### Kv / Cv values - 2/2-way valves

Connection				Size			Kv value*	Cv value
Size		Connection	Code	International code	DN	Actuator	l/min	US gal/min
1/2"	Tube	Flare connection	75	8	10	2	34.2	2.4
	Pipe	Metric butt weld spigot	20	-	15	2	82.5	5.7
3/4"	Tube	Flare connection	75	12	15	2	86.7	6.0
	Pipe	Metric butt weld spigot	20	-	20	2	83.7	5.8
	Pipe	Metric butt weld spigot	20	-	20	3	171.7	11.9
1"	Tube	Flare connection	75	16	20	2	93.3	6.5
	Pipe	Metric butt weld spigot	20	-	25	2	94.0	6.5
	Tube	Flare connection	75	16	20	3	183.3	12.7
	Pipe	Metric butt weld spigot	20	-	25	3	233.3	16.2
1 1/4"	Tube	Flare connection	75	20	25	3	238.3	16.6
	Pipe	Metric butt weld spigot	20	-	32	3	238.3	16.6

\* The measurement was carried out with water at 5 bar inlet pressure and a temperature of 20 °C.

RANGE OVERVIEW *CleanStar*® C60 / C67 2/2-WAY VALVES

Connection / availability							
Flare connection	Butt weld spigot		Connection		Actuator size	Dimensions see page	
	on both sides	on one side Pos. Z	Code international	DN		C60	C67
					2		
1/2" - 1/2"	15 - 15		8	10		1,5	6
			-	15		1,5	6
3/4" - 3/4"	20 - 20		12	15		1,5	6
			-	20		1,5	6
1" - 1"	25 - 25		16	20		1,5	6
			-	25	1,5	6	
	20 - 20	On request	-	20	3	1,5	6
1" - 1"			16	25		1,5	6
	25 - 25		-	25		1,5	6
1 1/4" - 1 1/4"			20	25		1,5	6
	32 - 32		-	32	1,5	6	

## Order data

Type	Code
Valve with pneumatic actuator	C60
Valve with manual operator	C67

Valve body material	Code
PP-H, grey	G5
PP-R, natural	R5

Nominal size	Code
Tube (1/2") DN 10	8
Pipe DN 15	15
Tube (3/4") DN 15	12
Pipe DN 20	20
Tube (1") DN 20	16
Pipe DN 25	25
Tube (1 1/4") DN 25	20
Pipe DN 32	32

Seal material	Code
PTFE/EPDM	5A

Control function	Code
Manually operated (C67 HPS)	0
Normally closed (C60 HPS)	1
Normally open (C60 HPS)	2
Double acting (C60 HPS)	3

Body configuration	Code
2/2-way body	D

Actuator version	Code
Actuator size 2	2
Actuator size 3	3
For defining the actuator size see pages 2 and 3	

Valve body connection	Code
Spigots for IR butt welding	20
Flare connection with PVDF union nut	75
Flare connection with PFA union nut	77

High Purity version	Code
HP Smartline	HPS

Order example	C60	8	D	75	G5	5A	1	2	HPS
Type	C60								
Nominal size (code)		8							
Body configuration (code)			D						
Valve body connection (code)				75					
Valve body material (code)					G5				
Seal material (code)						5A			
Control function (code)							1		
Actuator version (code)								2	
High Purity version (code)									HPS

### Dimensions 2/2-way valves C60HPS - actuator size 2

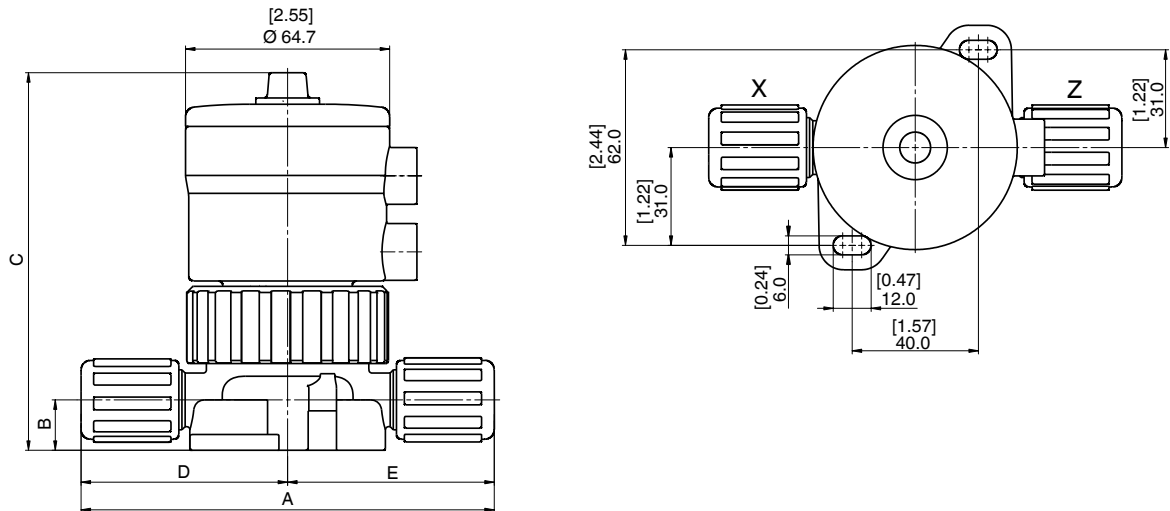

Connection		Dimensions [mm/inch]				
X	Z	A	B	C	D	E
DN15 Butt weld spigot	DN15 Butt weld spigot	131.0 / 5.15"	19 / 0.75"	124.5 / 4.90"	65.5 / 2.57"	65.5 / 2.57"
DN20 Butt weld spigot	DN20 Butt weld spigot	131.0 / 5.15"	19 / 0.75"	124.5 / 4.90"	65.5 / 2.57"	65.5 / 2.57"
DN25 Butt weld spigot	DN25 Butt weld spigot	145.0 / 5.70"	19 / 0.75"	124.5 / 4.90"	72.5 / 2.85"	72.5 / 2.85"
1/2" Flare connection	1/2" Flare connection	131.8 / 5.19"	16 / 0.63"	120.5 / 4.74"	65.9 / 2.59"	65.9 / 2.59"
3/4" Flare connection	3/4" Flare connection	133.8 / 5.27"	19 / 0.75"	124.5 / 4.90"	66.9 / 2.63"	66.9 / 2.63"
1" Flare connection	1" Flare connection	160.0 / 6.30"	19 / 0.75"	124.5 / 4.90"	80.0 / 3.15"	80.0 / 3.15"

### Dimensions 2/2-way valves C67HPS - actuator size 3

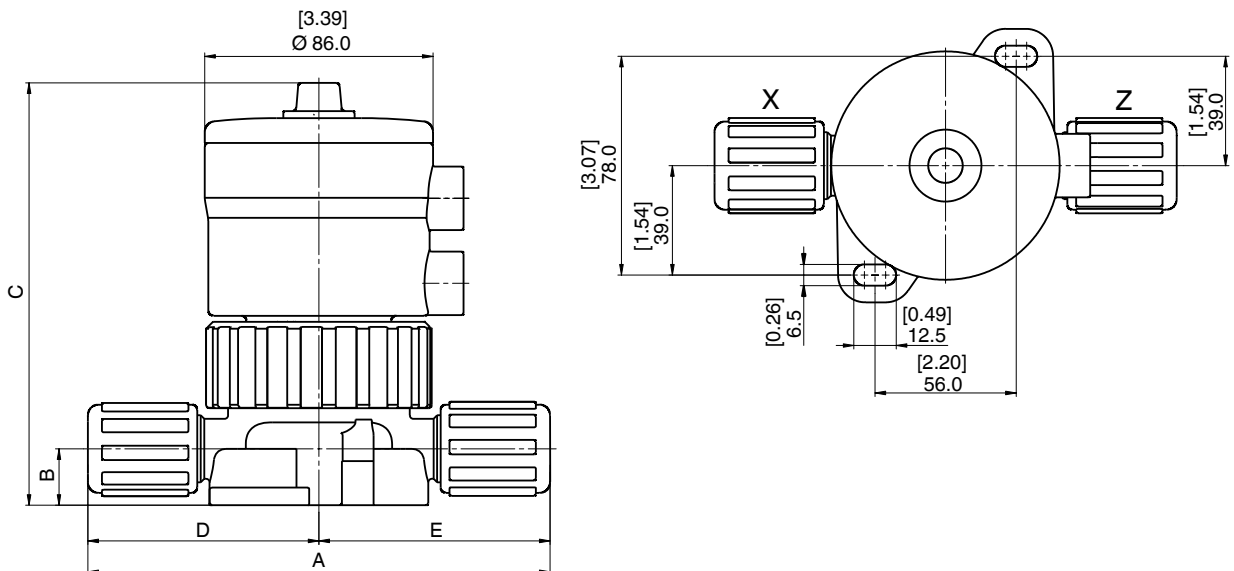

Connection		Dimensions [mm/inch]				
X	Z	A	B	C	D	E
DN20 Butt weld spigot	DN20 Butt weld spigot	166 / 6.54"	25 / 0.98"	160.5 / 6.31"	83 / 3.27"	83 / 3.27"
DN25 Butt weld spigot	DN25 Butt weld spigot	166 / 6.54"	25 / 0.98"	160.5 / 6.31"	83 / 3.27"	83 / 3.27"
DN32 Butt weld spigot	DN32 Butt weld spigot	172 / 6.77"	25 / 0.98"	160.5 / 6.31"	86 / 3.38"	86 / 3.38"
1" Flare connection	1" Flare connection	180 / 7.08"	25 / 0.98"	160.5 / 6.31"	90 / 3.54"	90 / 3.54"
1 1/4" Flare connection	1 1/4" Flare connection	192 / 7.56"	25 / 0.98"	160.5 / 6.31"	96 / 3.78"	96 / 3.78"

### Dimensions 2/2-way valves C67HPS - actuator size 2

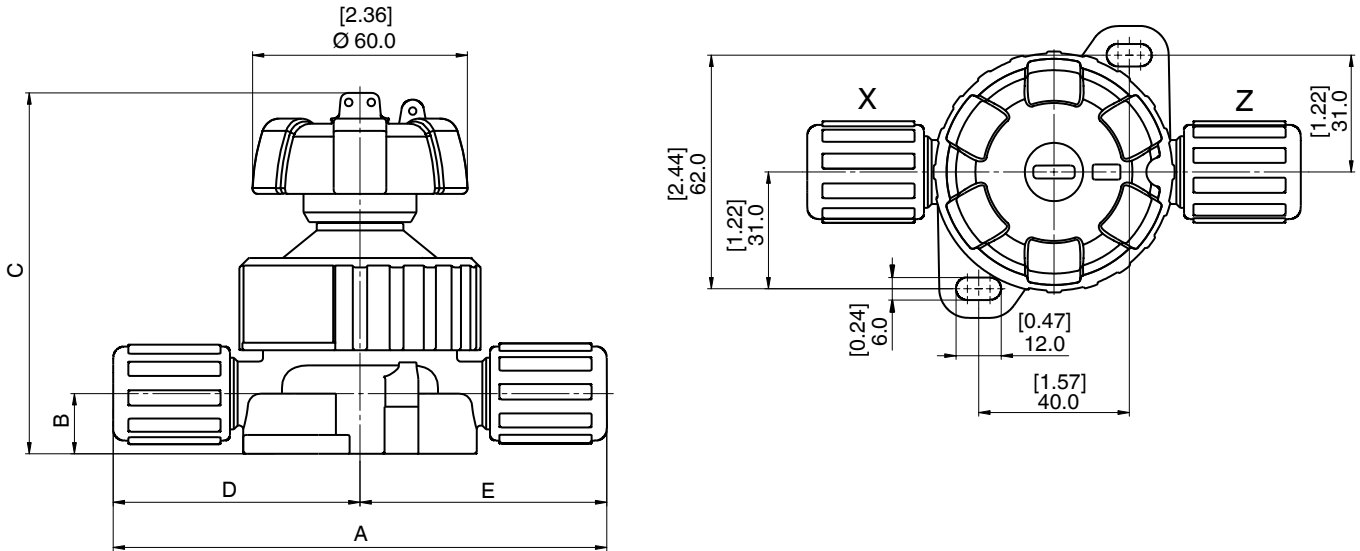

Connection		Dimensions [mm/inch]				
X	Z	A	B	C	D	E
DN15 Butt weld spigot	DN15 Butt weld spigot	131.0 / 5.15"	19 / 0.75"	109 / 4.29"	65.5 / 2.57"	65.5 / 2.57"
DN20 Butt weld spigot	DN20 Butt weld spigot	131.0 / 5.15"	19 / 0.75"	109 / 4.29"	65.5 / 2.57"	65.5 / 2.57"
DN25 Butt weld spigot	DN25 Butt weld spigot	145.0 / 5.70"	19 / 0.75"	109 / 4.29"	72.5 / 2.85"	72.5 / 2.85"
1/2" Flare connection	1/2" Flare connection	131.8 / 5.19"	16 / 0.63"	103 / 4.06"	65.9 / 2.59"	65.9 / 2.59"
3/4" Flare connection	3/4" Flare connection	133.8 / 5.27"	19 / 0.75"	109 / 4.29"	66.9 / 2.63"	66.9 / 2.63"
1" Flare connection	1" Flare connection	160.0 / 6.30"	19 / 0.75"	109 / 4.29"	80.0 / 3.15"	80.0 / 3.15"

### Dimensions 2/2-way valves C67HPS - actuator size 3

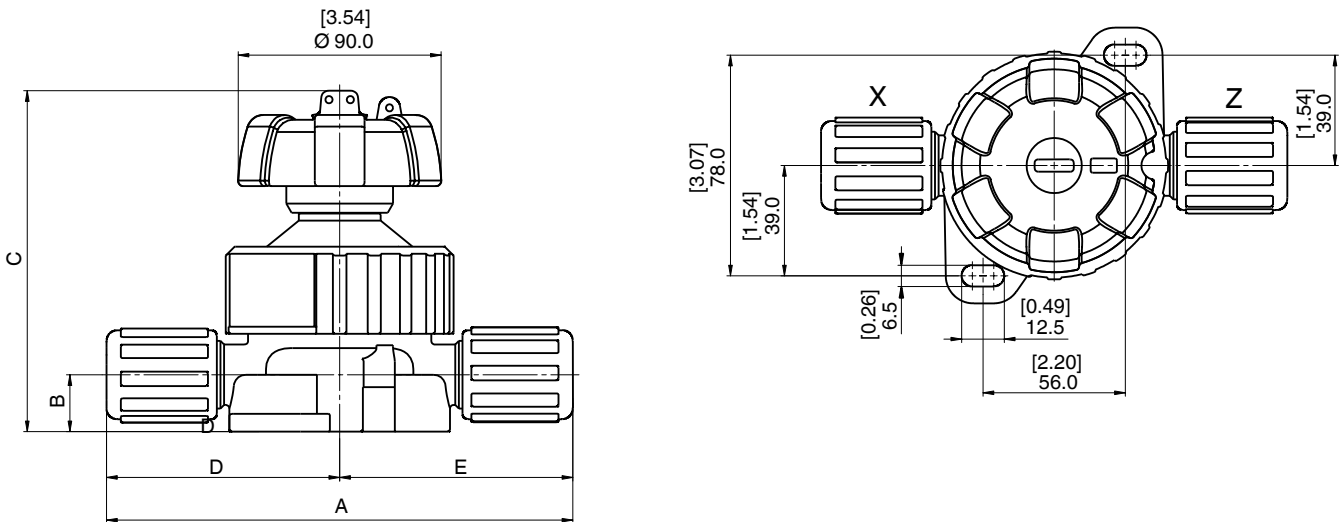

Connection		Dimensions [mm/inch]				
X	Z	A	B	C	D	E
DN20 Butt weld spigot	DN20 Butt weld spigot	166 / 6.54"	25 / 0.98"	145.0 / 5.71"	83 / 3.27"	83 / 3.27"
DN25 Butt weld spigot	DN25 Butt weld spigot	166 / 6.54"	25 / 0.98"	145.0 / 5.71"	83 / 3.27"	83 / 3.27"
DN32 Butt weld spigot	DN32 Butt weld spigot	172 / 6.77"	25 / 0.98"	145.0 / 5.71"	86 / 3.38"	86 / 3.38"
1" Flare connection	1" Flare connection	180 / 7.08"	25 / 0.98"	145.0 / 5.71"	90 / 3.54"	90 / 3.54"
1 1/4" Flare connection	1 1/4" Flare connection	192 / 7.56"	25 / 0.98"	145.0 / 5.71"	96 / 3.78"	96 / 3.78"

## Dimensions butt weld spigots (Code 20) [mm]

Connection				
DN	Actuator size	A	øB	C
15	2	33	20	1.9
20	2	33	25	2.3
25	2	33	32	3.0
20	3	40	25	2.3
25	3	33	32	3.0
32	3	33	40	3.7

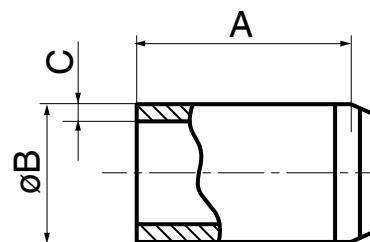

## Dimensions / Tolerances

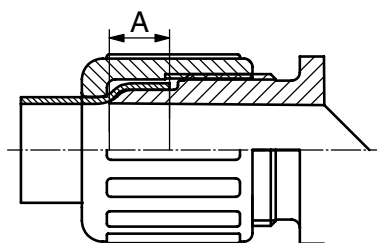

### Overlap dimensions and thread sizes of flare connections

Tube size	Thread designation	Standard	A mm [inch]
1/2"	3/4"-20-UNEF	ANSI B 1.1	12.0 [0.47"]
3/4"	1"-20-UNEF	ANSI B 1.1	14.0 [0.55"]
1"	1 7/16"-12-UN	ANSI B 1.1	14.0 [0.55"]
1 1/4"	1 3/4"-8-UN	ANSI B 1.1	18.0 [0.71"]

### Tolerances

- The **CleanStar®** plastic parts are manufactured to DIN 16901-140.
- Tolerance data for butt weld connections will vary depending on the design of the welding machine used.

## Accessories



**GEMÜ C67 STA**  
Service tool for actuators



**GEMÜ 1098**  
Flaring mandrel



**GEMÜ CF STF**  
Service tool for  
flare union nuts

## Other High Purity products



**HydraLine®**  
Pressure Measurement  
Systems



**PurePlus®**  
High Purity PVDF/PP  
Valves and Flowmeters



**SonicLine®**  
High Purity PFA  
Ultrasonic Flowmeters



**FlareStar®**  
Ultra pure PFA tube  
and weld fittings

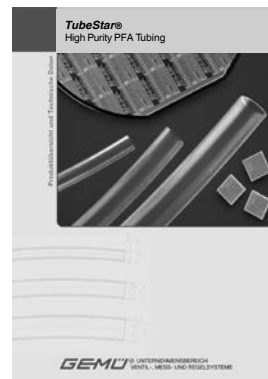

**TubeStar®**  
High Purity  
PFA Tubing

For further valves, high purity products, accessories and other products, please see our Product Range catalogue and Price List. Contact GEMÜ.

**GEMÜ®** VALVES, MEASUREMENT  
AND CONTROL SYSTEMS

