

HBA SERIES

Ultra-High Purity Bar Stock Stainless Steel
Air-Actuated Bellows Valves

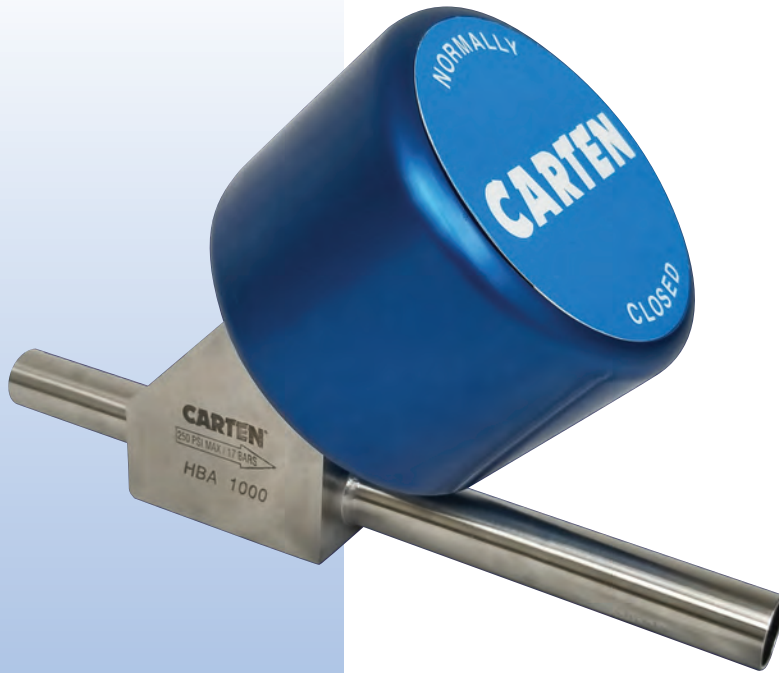

HBA SERIES

HBA Series Product Applications

This HBA series, pneumatically actuated bellows valve, has an innovative visual open/closed indicator with a visible signal when the valve is in an open/closed position. The unique design enables this valve to achieve flows at low to medium operating pressures to make this range an excellent consideration for:

- High-purity gas distribution system control
- High-purity gas valves for point-of-use service
- Superior containment and cleanliness for your most critical valve applications
- Use with inert and most toxic gases

HBA Series Product Features

- Air-Actuated Bellows Valve, Compact Design, and Long Cycle Life
- Ultra-High Purity Bar Stock Stainless Steel/PCTFE/Vespel® Valve Construction
- 10 Ra Max – Electropolished Surface Finish – Std (Optional Surface Finishes Available)
- Purge Connections and Purge Valves are Integrated in Valve Body
- Valve Body and Tube Stubs are Serialized for Material Certification

HBA Construction Materials

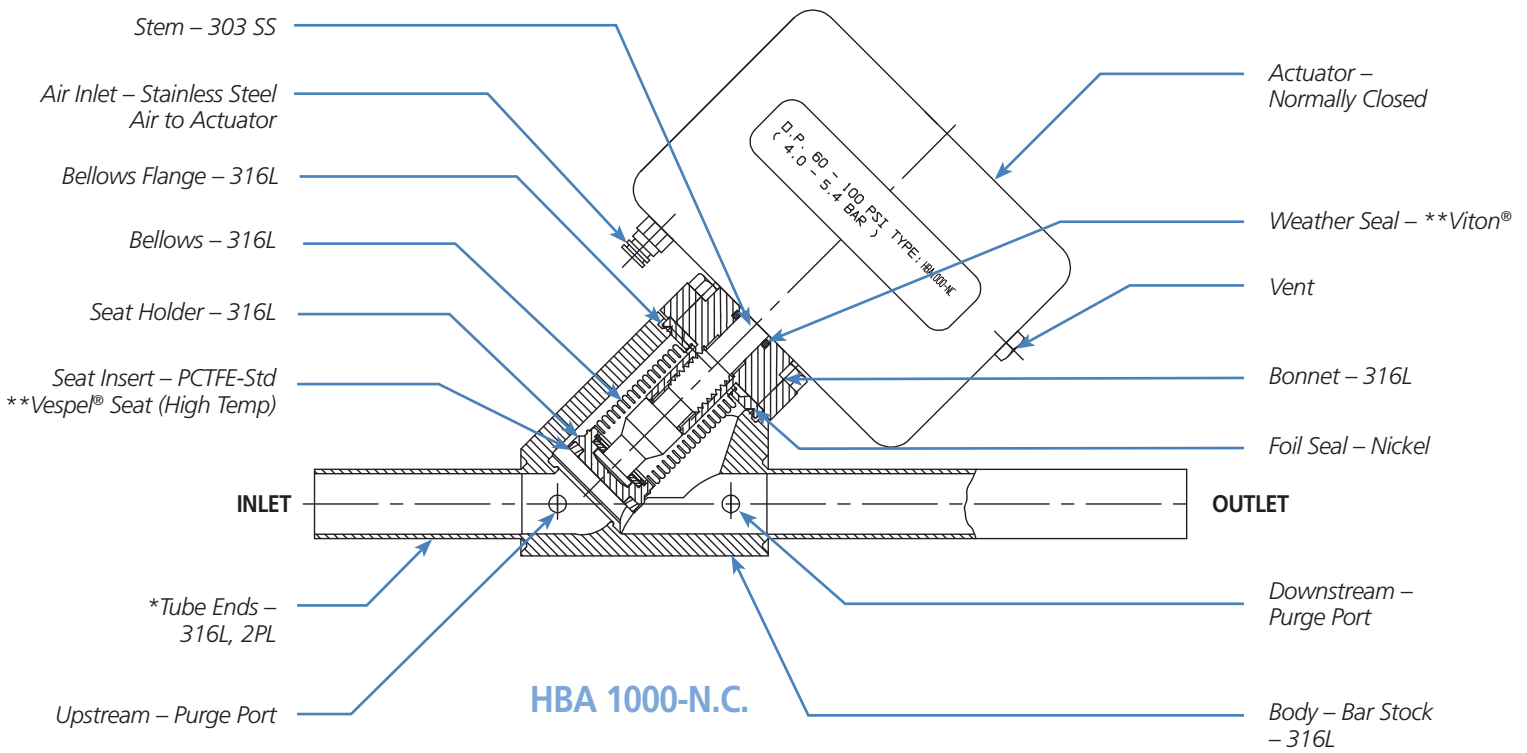

*See Ordering Code for other available – Valve FSM - M/F Connection Ends – sizes 750/1000.

**Vespel® Viton® are registered trademarks of DuPont Company.

HBA SERIES

HBA Series Technical Data

MATERIAL OF CONSTRUCTION	Wetted Areas	316L Stainless Steel, PCTFE, Nickel	
	Non-Wetted Areas	316L Stainless Steel, *Viton®, 303 SS, Phenolic	
MAXIMUM OPERATING PRESSURE	HBA 751/1000/1501 (- NC / - NO)	Vacuum to 250 psig (17.2 bar)	60-100 psig (4.1 to 6.5 bar) - Actuators
	HBA 1502/2000/3002 (- NC-ID / - NO-ID)		
	HBA 3004/4000/6004 (- NC-ID)		
MAXIMUM OPERATING TEMPERATURE	PCTFE Seat – Std **Vespel® Seat (High Temp)	-22°F (-30°C) to 180°F (82°C) 181°F (83°C) to 302°F (150°C)	

**Vespel® and Viton® are registered trademarks of DuPont Company.

VALVE MODELS Valve Sizes	BODY DATA Tube/Body (Seat-Orifice) Sizes	FLOW COEFFICIENT (C _v)	WEIGHT	
			LBS	(KG)
HBA 751	Ø.750 / 1.000 (Ø1.06 in. (Ø27.0mm)-Orifice)	10.2	13.5	(6.1)
HBA 1000	Ø1.000 / 1.000 (Ø1.06 in. (Ø27.0mm)-Orifice)	14.3	13.0	(5.9)
HBA 1501	Ø1.500 / 1.000 (Ø1.06 in. (Ø27.0mm)-Orifice)	16.6	14.4	(6.4)
Actuators - (- NC / - NO)				
HBA 1502	Ø1.500 / 2.000 (Ø2.12 in. (Ø53.8mm)-Orifice)	63.3	43.5	(19.7)
HBA 2000	Ø2.000 / 2.000 (Ø2.12 in. (Ø53.8mm)-Orifice)	74.1	43.1	(19.5)
HBA 3002	Ø3.000 / 2.000 (Ø2.12 in. (Ø53.8mm)-Orifice)	78.0	44.2	(20.0)
Actuators - (- NC-ID / - NO-ID)				
HBA 3004	Ø3.000 / 4.000 (Ø3.50 in. (Ø88.9mm)-Orifice)	175.0	120.4	(54.6)
HBA 4000	Ø4.000 / 4.000 (Ø3.50 in. (Ø88.9mm)-Orifice)	181.0	119.0	(54.0)
HBA 6004	Ø6.000 / 4.000 (Ø3.50 in. (Ø88.9mm)-Orifice)	185.0	127.9	(58.0)
Actuators - (- NC-ID)				

HELIUM LEAK TEST	Inboard Across the Seat Outboard Pressure Test	≤ 1 x 10 ⁻⁹ std.cc (atm) He / sec ≤ 1 x 10 ⁻⁹ std.cc (atm) He / sec ≤ 1 x 10 ⁻⁶ std.cc (atm) He / sec
CLEANLINESS AND PACKAGING	Assembled and tested in Class 100 Cleanroom. Purged and Final Packaged in Class 1 Cleanroom. Double-bag Packaging (2 mil nylon inner bag, 6 mil polyethylene outer bag) with Ultra-High Purity N ₂ gas environment.	
STANDARD FINISH	10 Ra Max – Electropolished Surface Finish – Std (Optional surface finishes available)	
NOTES AND OPTIONS	Testing: Particle, Moisture, O ₂ , SEM, ESCA, and AES Purge Connections – Valve Type/Location – Sizes .250 / .500 Valve Connection Ends – Inlet/Outlet Sizes .750/1.000 Valve Body Mounting Holes Std. Options: 1) HBA 1000 – .250-20 UNC-2B 2) HBA 2000 – .375-16 UNC-2B 3) HBA 4000 – .375-16 UNC-2B Valve Body Flanged Ends – Rotatable Pneumatic Type Actuator Types Available: NC – Normally Closed – Requires Air to Open and Spring to Close NC-ID – Normally Closed with Indicator to Show Actuation Position NO – Normally Open – Requires Air to Close and Spring to Open NO-ID – Normally Open with Indicator to Show Actuation Position	

Specifications are subject to change without notice.

HBA SERIES



HBA Series Technical Dimensions

SERIES/SIZE (INCH)	A	B	C	D	E	F	G
HBA 751	Ø.750 (19.1mm)	0.065 (1.65mm)	0.75 (19.1mm)	4.06 (10.3mm)	7.06 (179.3mm)	14.61 (371.1mm)	11.91 (303.5mm)
HBA 1000	Ø1.000 (25.4mm)	0.065 (1.65mm)	0.75 (19.1mm)	3.04 (77.2mm)	6.06 (153.9mm)	12.61 (320.3mm)	10.91 (277.1mm)
HBA 1501	Ø1.500 (38.1mm)	0.065 (1.65mm)	0.75 (19.1mm)	5.01 (127.3mm)	8.01 (203.5mm)	16.51 (419.4mm)	12.86 (326.6mm)
Actuators - (- NC / - NO)							
HBA 1502	Ø1.500 (38.1mm)	0.065 (1.65mm)	1.25 (31.7mm)	5.01 (127.3mm)	9.01 (228.9mm)	19.48 (494.8mm)	18.34 (465.8mm)
HBA 2000	Ø2.000 (50.8mm)	0.065 (1.65mm)	1.25 (31.7mm)	4.06 (103.1mm)	8.06 (204.7mm)	17.58 (446.5mm)	17.39 (441.7mm)
HBA 3002	Ø3.000 (76.2mm)	0.065 (1.65mm)	1.25 (31.7mm)	7.91 (200.9mm)	10.91 (277.1mm)	24.28 (616.7mm)	21.24 (539.5mm)
Actuators - (- NC - ID)							
HBA 1502	Ø1.500 (38.1mm)	0.065 (1.65mm)	1.25 (31.7mm)	5.01 (127.3mm)	9.01 (228.9mm)	19.48 (494.8mm)	17.09 (434.1mm)
HBA 2000	Ø2.000 (50.8mm)	0.065 (1.65mm)	1.25 (31.7mm)	4.06 (103.1mm)	8.06 (204.7mm)	17.58 (446.5mm)	16.14 (410.0mm)
HBA 3002	Ø3.000 (76.2mm)	0.065 (1.65mm)	1.25 (31.7mm)	7.91 (200.9mm)	10.91 (277.1mm)	24.28 (616.7mm)	19.99 (507.8mm)
Actuators - (- NO - ID)							
HBA 3004	Ø3.000 (76.2mm)	0.065 (1.65mm)	2.13 (54.1mm)	8.04 (204.2mm)	10.04 (255.0mm)	25.47 (646.9mm)	24.44 (620.8mm)
HBA 4000	Ø4.000 (101.6mm)	0.083 (2.11mm)	2.13 (54.1mm)	4.20 (106.7mm)	8.20 (208.3mm)	19.79 (502.7mm)	20.60 (523.2mm)
HBA 6004	Ø6.000 (152.4mm)	0.109 (2.77mm)	2.13 (54.1mm)	11.78 (299.2mm)	11.78 (299.2mm)	30.95 (786.1mm)	28.18 (715.8mm)
Actuators - (- NC - ID)							

NOTE 1: All tolerances are ± 0.06 in. (± 1.52 mm) unless otherwise stated.

NOTE 2: Dimensional drawings shown are for reference only. Please contact CARTEN® for customer drawings.

HBA SERIES

HBA Series Typical Valve Dimensions (1/2" to 6")

HBA 1000 BODY (N.C. OR N.O. ACTUATORS) 751 / 1000 / 1501

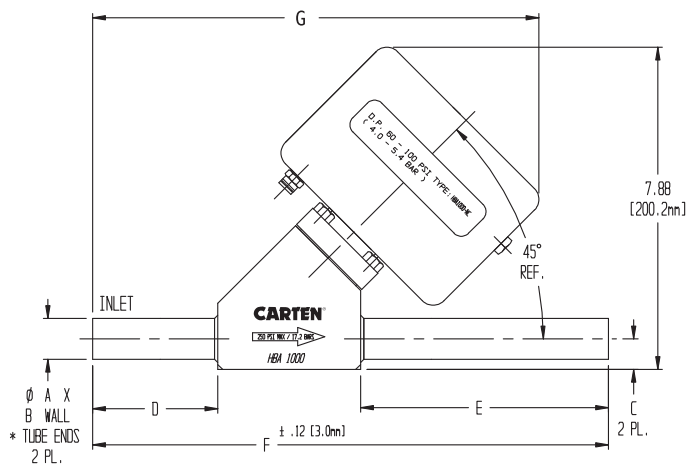

* See Ordering Code for other available
FSM - M/F connection ends.

HBA 2000 BODY (N.C. -ID OR N.O. -ID ACTUATORS) 1502 / 2000 / 3002

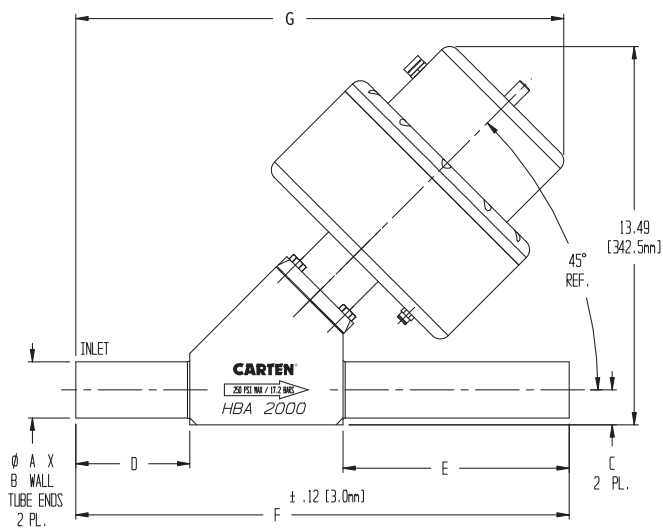

HBA 4000 BODY (N.C. -ID ACTUATORS) 3004 / 4000 / 6004

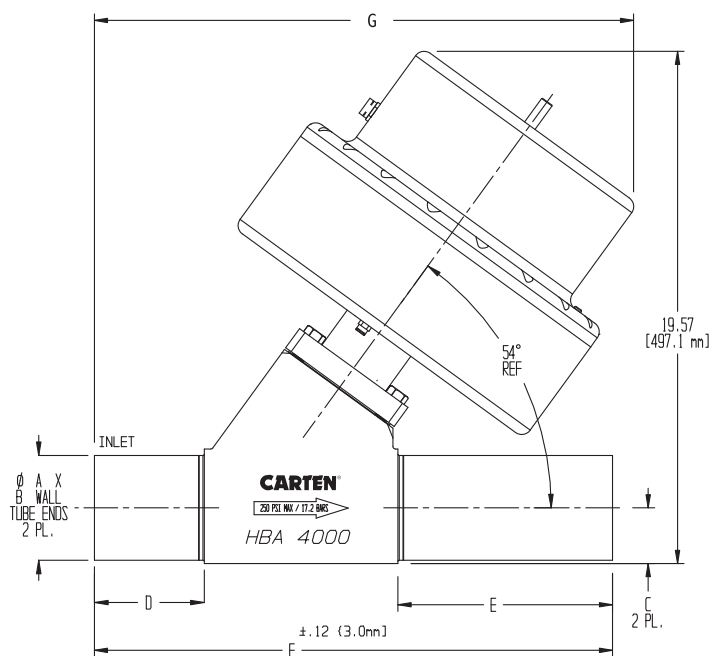

HBA SERIES

HBA Series Ordering Code

HBA – **1000** – **10** – **PC2** – **FSM-MR** – **NC**

SERIES	TYPE
HBA	Pneumatic

CODE	SURFACE FINISH
10	10 Ra Max - Std EP
20	20 Ra Max - EP

CODE	TYPE
FSM-MR	Fixed Male-RH

FSM – Face Seal Metal Purge
(Right Hand)

VALVE SIZES	TUBE/(BODY) INCH – SIZES	
HBA 751	Ø.750	(1.000)
HBA 1000	Ø1.000	
HBA 1501	Ø1.500	
HBA 1502	Ø1.500	(2.000)
HBA 2000	Ø2.000	
HBA 3002	Ø3.000	
HBA 3004	Ø3.000	(4.000)
HBA 4000	Ø4.000	
HBA 6004	Ø6.000	

CODE	SIZE/LOCATION	TYPE
LV	Not Required	None
PC1	1/4" Downstream	Purge
PC2	1/4" Up & Downstream	Purge
PC3	1/4" Upstream	Purge
PV1	1/4" Downstream	Valve
PV2	1/4" Up & Downstream	Valve
PV3	1/4" Upstream	Valve
PC15	1/2" Downstream	Purge
PC25	1/2" Up & Downstream	Purge
PC35	1/2" Upstream	Purge
PV15	1/2" Downstream	Valve
PV25	1/2" Up & Downstream	Valve
PV35	1/2" Upstream	Valve

1/2" size connection type not available on all sizes.
Please contact CARTEN® for availability.

CODE	OPTIONS
Pneumatics	
NC	Normally Closed
NC-ID	Normally Closed w/ Indicator
NO	Normally Open
NO-ID	Normally Open w/ Indicator
V	SEAT – *Vespel®
R	Rotatable Flange

*Vespel® is a registered trademark of DuPont Company.

OPTIONAL VALVE FSM - M/F CONNECTION ENDS

Available on HBA Series .750" - 1" Body Sizes

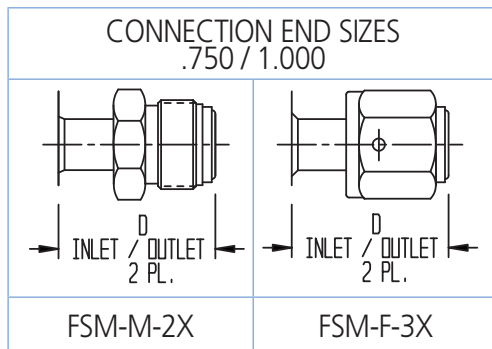

Connection Size	Dimension "D"	
	FSM-M-2X	FSM-F-3X
.750	2.04 (51.8mm)	2.04 (51.8mm)
1.000	2.38 (60.5mm)	2.38 (60.5mm)

Safe Product Selection

When selecting a product, the total system design must be considered to ensure safe, trouble-free performance. Function, material compatibility, adequate ratings, proper installation, operation, and maintenance are the responsibilities of the system designer and user.

Carten Fujikin, Inc.
604 West Johnson Avenue
Cheshire, Connecticut CT 06410 USA

Tel: +1 203-699-2100
Fax: +1 203-699-2179
Email: sales@cartenus.com
Website: www.cartenus.com

REV 11/2019

CARTEN®

High Performance Valves & Process Flow Solutions

Carten Controls, Ltd.
Unit 609, Waterford Industrial Park
Waterford, X91 AX05 Ireland

Tel: +353 (0)51 355436
Fax: +353 (0)51 378054
Email: sales@cartencontrols.com
Website: www.cartencontrols.com

Carten Controls is a member of Fujikin Corp Group (FCG)
with Headquarters in Osaka, Japan.